

## Δελτίον της Χριστιανικής Αρχαιολογικής Εταιρείας

Τόμ. 28 (2007)

Δελτίον ΧΑΕ 28 (2007), Περίοδος Δ'. Στη μνήμη του Παύλου Μ. Μυλωνά (1915-2005)

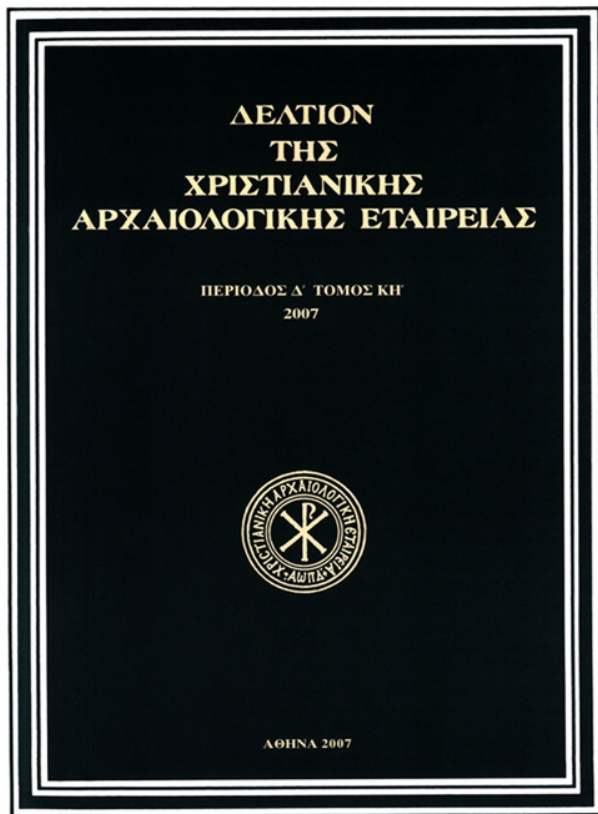

Σχέδιο κατόψεως της όψιμης αρχαιότητας στην Αθήνα

Charalambos BOURAS

doi: [10.12681/dchae.571](https://doi.org/10.12681/dchae.571)

### Βιβλιογραφική αναφορά:

BOURAS, C. (2011). Σχέδιο κατόψεως της όψιμης αρχαιότητας στην Αθήνα. *Δελτίον της Χριστιανικής Αρχαιολογικής Εταιρείας*, 28, 31–34. <https://doi.org/10.12681/dchae.571>



# ΔΕΛΤΙΟΝ ΤΗΣ ΧΡΙΣΤΙΑΝΙΚΗΣ ΑΡΧΑΙΟΛΟΓΙΚΗΣ ΕΤΑΙΡΕΙΑΣ

## A Sketch Plan of Late Antiquity in Athens

---

Charalambos BOURAS

Περίοδος Δ', Τόμος ΚΗ' (2007) • Σελ. 31-34

ΑΘΗΝΑ 2007

## A SKETCH PLAN OF LATE ANTIQUITY IN ATHENS

In Byzantium, the way in which the architectural idea took form and became an actual building is little known. The written evidence is scant and equivocal and the importance of the original design to the end product is uncertain<sup>1</sup>. Examination both of texts and of finds has yielded many conclusions in the case of Roman architecture<sup>2</sup>, few in the case of Early Christian<sup>3</sup>, and hardly any for the Middle Byzantine period<sup>4</sup>. Any document such as a drawing, however insignificant it may seem to be, is therefore very welcome to historians of architecture.

What kind of drawings are to be expected in Byzantium at all periods? Nothing comparable with modern drawings, of course, but far simpler; a drawing that expressed the idea of the work of architecture<sup>5</sup>, primarily *ichnographia* drawings according to Vitruvius<sup>6</sup> – that is, ground plans. In fact today, even people unconnected with architecture make rough drawings of ground plans when they are trying to describe a building. The Roman<sup>7</sup> and the very few Byzantine<sup>8</sup> drawings that have been preserved are almost all ground plans.

On the marble floor of the porch of the Pompeion in Athens is preserved a small drawing or sketch that deserves comment. The Pompeion was built in the fourth c. BC very close to the western gates of Athens and is preserved in ruins<sup>9</sup>. Its building phases have been closely studied and interpreted by W. Hoepfner<sup>10</sup>, who also published very accurate drawings

of it<sup>11</sup>. Naturally enough, this scholar noted the “drawing” and the other naive graffiti with their incomprehensible inscriptions, and commented merely that it depicts a ground plan or a vase<sup>12</sup>.

Part of the paving and the east part of the crepis of the porch were removed when, in the Late Roman period, a new monumental entrance was created for the complex of stoas that succeeded the earlier phases of the Pompeion. The west part of the paving of the porch, however, was quite well preserved with just a few scratches and traces of blows<sup>13</sup>.

The “drawing” is on a paving slab between the wall with the door and the prosthesis of the porch, which still existed at this date, about 1.70 m from the threshold of the south door of the porch. It is fairly small, with a total length of about nine cm. and with the diameter of the circle measuring six cm. It cannot be called a graffito, since the lines of which it is formed were made by a small striking tool and not a simple pointed instrument (Fig. 1).

The “drawing” does not suggest any specific purpose, but, on the contrary, has a makeshift, naive appearance. The ground plan is not regular in geometrical terms and is rendered with simple lines, with no indication of the thickness of the walls. It depicts a circular building with two symmetrical apses flanking a rectangular extension that ends in two perceptibly smaller apses and has an indistinct end, that was perhaps not completed. Diametrically opposite this exten-

<sup>1</sup> The statement that the architectural design was not practised by the Byzantines is expressed by R. Ousterhout, *Master Builders of Byzantium*, Princeton 1999, 58-85. For the opposite views see Ch. Bouras, “Originality in Byzantine Architecture”, *Melanges J.P. Sordini*, TM 15, Paris 2005, 107-8.

<sup>2</sup> The main source of information is the Treatise of Vitruvius *On Architecture*. For the archaeological evidence see M. Wilson Jones, *Principles of Roman Architecture*, New Haven-London 2000, 19ff.

<sup>3</sup> Α. Κ. Ὁρλάνδος, *Ἡ ξυλόστεγος παλααιοχριστιανική βασιλική τῆς μεσογειακῆς λεκάνης*, Athens 1954, 26-34. The sending of drawing (σκάριφος) from the Capital to Gaza, for the building of a church, is mentioned in the *Vita* of St. Porphyrios (Chapter 75).

<sup>4</sup> Ousterhout, *op.cit.*, 58ff.

<sup>5</sup> Vitruvii, *De architectura*, P. Lefas ed., Athens 2000, vol. 1, 50-1, Comments, 94.

<sup>6</sup> *Ibid.*, 50, 51 n. 78.

<sup>7</sup> Wilson Jones, *op.cit.*, figs 26, 27, 49-59.

<sup>8</sup> Ousterhout, *op.cit.*, figs 34, 35, 40, 43.

<sup>9</sup> J. Travlos, *Pictorial Dictionary of Ancient Athens*, London 1971, 477-81.

<sup>10</sup> W. Hoepfner, *Das Pompeion und seine Nachfolgerbauten*, Kerameikos X, Berlin 1976.

<sup>11</sup> *Ibid.*, figs 154, 157, 158, 174, 175, 183-185, 190, 204, pls 15-18, 24.

<sup>12</sup> *Ibid.*, figs 144, 145, 160, 161.

<sup>13</sup> *Ibid.*, pl. 24.



Fig. 1. Athens. Propylon of the Pompeion. Sketch plan on the marble pavement.

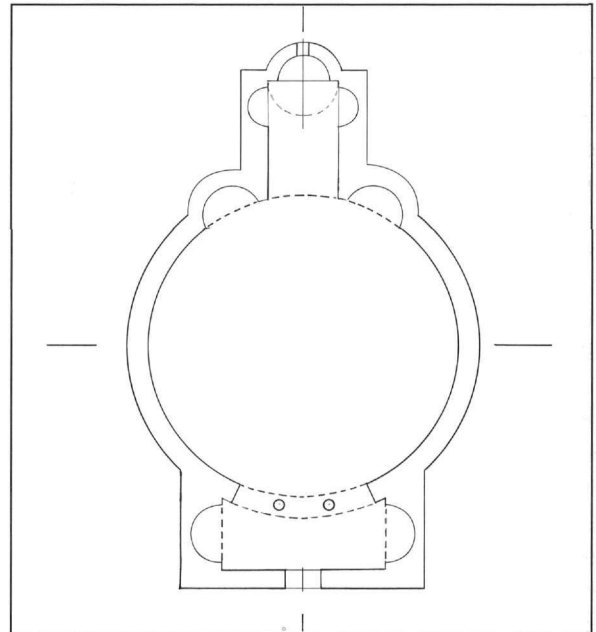

Fig. 2. Attempt to interpret the sketch of the Fig. 1, with a modern drawing.

sion is a vestibule with niches inscribed in a rectangle in the two narrow sides. One distinct and one indistinct hole in the marble may be interpreted as columns.

The drawing in Fig. 2 is an attempt to reproduce in a modern architectural manner the design that the anonymous Athenian idler tried to give an idea of in his naive drawing: a centralised building that had an extension, probably roofed with a barrel vault on one side and with a triconch end, and a vestibulum made wider with side niches, which opened into the circular room by way of a tribelon.

All these features undoubtedly suggest the architecture of Late Antiquity, and specifically large centralised buildings such as the mausoleums, martyria<sup>14</sup> or churches of the period. The idea of not disrupting the main centralised space by including

the sanctuary in it led in the case of some churches to the addition of a self-contained area to house its functions. The best-known example is the church known as Ayios Georgios or the Rotunda in Thessaloniki<sup>15</sup>, a Late Roman building that, when it was converted into a church, acquired a barrel-vaulted extension at the east, housing the sanctuary apse. Other circular buildings (though involving a variety of problems with regard to their reconstruction) noted are the martyrium of Ayios Karpos in Constantinople<sup>16</sup>, with a concentric interior stylobate (?), the cathedral of Skythopolis<sup>17</sup> (Beth Shean), also with an concentric interior nucleus, and the church of Fal'al in Syria<sup>18</sup>, with later (?) pastophoria either side of the projecting sanctuary and a porch or vestibule at its west end.

The same arrangement of the sanctuary is to be found in

<sup>14</sup> A. Grabar, "Martyrium", *Recherches sur le culte des reliques et l'art chrétien antique*, Paris 1946, 141-52.

<sup>15</sup> Ν. Μουτσόπουλος, "Η παλαιοχριστιανική φάση της Ροτόντας του Αγίου Γεωργίου Θεσσαλονίκης", *Πρακτικά του Συνεδρίου Χριστιανικής Αρχαιολογίας*, Β', Thessaloniki 1984, 355-75. Κ. Θεοχαρίδου, "Η Ροτόντα της Θεσσαλονίκης, Νέα Στοιχεία... με αφορμή τις αναστηλωτι-

κές εργασίες", *ΔΧΑΕ ΙΣΤ'* (1991-1992), 57-76.

<sup>16</sup> A. M. Schneider, "Byzanz", *IstForsch* 8 (1936), 416-9. W. Müller-Wiener, *Bildlexikon zur Topographie Istanbuls*, Tübingen 1977, 186-7.

<sup>17</sup> C. S. Fisher, "The Church of Beisan", *Penn. Museum Journal* 15 (1924), 171ff.

<sup>18</sup> H. C. Butler, *Early Churches in Syria*, Princeton 1929, 164ff.

other centralised buildings, such as the tetraconch buildings of Seleukeia-Pieria<sup>19</sup> and Apameia<sup>20</sup>, the octagonal structures of the so-called tomb of the Virgin in Jerusalem<sup>21</sup> and of Souvasa<sup>22</sup>, the triconch building at Amida (Diarbekir)<sup>23</sup>, and the circular church with an octagonal nucleus at Constantini (Viran Kehir)<sup>24</sup>.

The two conches projecting either side of the church are almost unknown in the monuments of Late Antiquity, but it is not clear what the creator of the 'drawing' intended to represent by them, especially since small niches inscribed within walls were not unknown in buildings of this period<sup>25</sup>.

The tribelon (if it is indeed a tribelon) between the vestibule or narthex and the main area was very common in Early Christian basilicas, especially in Greece<sup>26</sup>. It was an architectural device that made it possible to isolate the narthex visually while allowing that was happening in the nave to be heard.

The vestibulum with two conches at the ends, was a common element in Late Roman architecture, as at Rome (Santa Constanza<sup>27</sup>, Sant Agnese<sup>28</sup>, Lateran baptistery<sup>29</sup>, Ginnio Baso basilica<sup>30</sup>, and in an annex of the Minerva Medica<sup>31</sup>) and subsequently in the Early Christian Octagon in Thessaloniki<sup>32</sup>, baptisteries in the basilica at Lechaion<sup>33</sup>, Ayios Georon in Cologne<sup>34</sup>, and a basilica at Klazomenai<sup>35</sup>. The schema, sometimes with full side niches (Nea Moni on

Chios<sup>36</sup>) and sometimes with shallow ones (katholikon of the Lips Monastery<sup>37</sup>, Myrelaion<sup>38</sup>, Pantepoptes<sup>39</sup>, katholika of Hosios Loukas<sup>40</sup> and Daphni<sup>41</sup>, Sotira Christianou<sup>42</sup>), also survived in Middle Byzantine architecture, without any obvious functional role.

From what has been said above, it is very probable that the sketch in the floor of the Pompeion represents a centralised church with architectural features that were in use in the general area of the Byzantine empire from the fourth to the sixth century. In his study of the phases of the Pompeion, W. Hoepfner took the view that in the second century the floor of the porch was already covered with earth fill and that later, in the Late Roman period, an even thicker permanent fill<sup>43</sup> was created after the construction of a heavy wall as the foundations for four clusters of four columns to give the gate a monumental appearance<sup>44</sup>. In order to seat this wall, however, as has already been noted, all the marble members of the east crepis of the Classical propylon and also a large part of its paving were removed: this implies that the fill had already been removed for a time and part of the marble paving of the floor had remained uncovered. Precise dates cannot be assigned to the Late Roman annexes<sup>45</sup>, given that the presumed clusters of four columns have disappeared, but the hypothesis that the 'drawing' was made during the fourth or fifth century does not seem to be far from the truth.

31 July 2006

<sup>19</sup> E. Kleinbauer, "Tetraconch Churches", *DOP* 27 (1973), 103, fig. 2.

<sup>20</sup> *Ibid.*, fig. 6.

<sup>21</sup> A. Grabar, *L'âge d'or de Justinien*, Paris 1966, 54, fig. 430.

<sup>22</sup> H. Rott, *Kleinasiatische Denkmäler*, Leipzig 1908.

<sup>23</sup> G. Lawthian Bell, M. Mundel Mango, *Tur Abdin*, London 1982, 107-8 (drawing after S. Guyer).

<sup>24</sup> *Ibid.*, 154-7. M. v. Berchen, J. Strzygowski, *Amida*, Heidelberg 1910.

<sup>25</sup> As in the Cathedral of Bosra. See B. Brenk, *Spätantike und frühes Christentum*, PKG, Suppl., 1977, 231, fig. 63.

<sup>26</sup> Α. Κ. Ὁρλάνδος, *Ἡ ξυλόστεγος παλαιοχριστιανική βασιλική τῆς μεσογειακῆς λεκάνης*, Α', Athens 1952, 148, n. 2-5.

<sup>27</sup> Brenk, *op.cit.*, 121-2, fig. 6.

<sup>28</sup> C. Cecchelli, *Monumenti christiano-eretici di Roma*, Rome 1944, 22.

<sup>29</sup> Brenk, *op.cit.*, 125, fig. 10.

<sup>30</sup> L. Crema, *L'architettura romana*, Rome 1959, 582, fig. 768.

<sup>31</sup> *Ibid.*, 631, fig. 838.

<sup>32</sup> Γ. Κνιθάκης, "Το Οκτάγωνο της Θεσσαλονίκης. Νέα προσπάθεια αναπαράστασής", *ADelt* (1975), Μελέται, 90-119.

<sup>33</sup> Δ. Πάλλας, "Ανασκαφή ἐν Λεχαίῳ", *ΠΑΕ* 1961, 137-45, figs 1, 2.

<sup>34</sup> R. Krautheimer, *Early Christian and Byzantine Architecture*, Harmondsworth 1986, 86, fig. 43.

<sup>35</sup> G. Weber, "Basilica und Baptisterium in Gül-Bagtsche", *BZ* X (1901), 570.

<sup>36</sup> Ch. Bouras, *Nea Moni on Chios*, Athens 1982, 60, figs 27, 30, 32, 33.

<sup>37</sup> Th. Macridy, "The Monastery of Lips (Fenari Isa Camii) in Istanbul", *DOP* 18 (1964), fig. 5 (plan by E. Mamboury).

<sup>38</sup> C. Striker, *The Myrelaion (Bodrum Camii) in Istanbul*, Princeton 1981, figs 1, 6, 19.

<sup>39</sup> A. Van Millingen, *Byzantine Churches in Constantinople*, London 1912, 212-6, fig. 73.

<sup>40</sup> R. W. Schultz, S. H. Barnsley, *The Monastery of Saint Luke of Stiris in Phokis*, London 1901, pls 1, 4.

<sup>41</sup> G. Millet, *Le monastère de Daphni*, Paris 1899, 50, fig. 24.

<sup>42</sup> E. Stikas, *L'église byzantine de Christianou*, Paris 1951, 19, pl. 1.

<sup>43</sup> Hoepfner, *op.cit.* (n. 10), 178, 186, pls 14, 17.

<sup>44</sup> *Ibid.*, 189, fig. 204.

<sup>45</sup> *Ibid.*, 188-9.

## ΣΧΕΔΙΟ ΚΑΤΟΨΕΩΣ ΤΗΣ ΟΨΙΜΗΣ ΑΡΧΑΙΟΤΗΤΑΣ ΣΤΗΝ ΑΘΗΝΑ

Στην πλακόστρωση του προπύλου του Πομπίου στην δυτική έξοδο των αρχαίων Αθηνών, υπάρχει ένα λαξευμένο μικρό σχέδιο κατόψεως (Εικ. 1). Το σχέδιο αυτό δεν υποδηλώνει συγκεκριμένο σκοπό αλλά μάλλον προχειρότητα και αφέλεια. Οι τοίχοι σχεδιάζονται με απλές γραμμές, οι αναλογικές όμως σχέσεις είναι σωστές. Στο σχέδιο της Εικ. 2 γίνεται μια απόπειρα να αποδοθεί το παριστανόμενο με σύγχρονο τρόπο. Φαίνεται λοιπόν ότι το σχέδιο προσπαθεί να δώσει την ιδέα ενός μεγάλου περίκεντρου κτηρίου της ύστερης αρχαιότητας με επίμηκες ιερό βήμα, πλάγιες κόγχες και νάρθηκα επίσης με πλάγιες κόγχες, ο οποίος επικοινωνούσε με τον κυρίως ναό μέσω τριβήλου. Όλα αυτά τα

στοιχεία παραλληλίζονται με άλλα γνωστών μνημείων της ύστατης αρχαιότητας, εκκλησιών η μαρτυριών.

Η χρονολόγηση του σχεδίου δεν είναι εύκολη. Φαίνεται όμως ότι η πλακόστρωση του προπύλου έμεινε ελεύθερη από επιχώσεις κατά κάποιο μικρό (;) χρονικό διάστημα τον 4ο ή τον 5ο αιώνα, όταν συστηματικά αφαιρέθηκε ένα τμήμα της, προκειμένου να γίνει μια νέα διαμόρφωση του χώρου.

Το μικρό σχέδιο του Πομπίου δεν στερείται ενδιαφέροντος λαμβανομένου υπ' όψη ότι ελάχιστα σχέδια έχουν διασωθεί από την υστάτη αρχαιότητα ή το Βυζάντιο.