

## Δελτίον της Χριστιανικής Αρχαιολογικής Εταιρείας

Τόμ. 4 (1966)

Δελτίον ΧΑΕ 4 (1964-1965), Περίοδος Δ'. Στη μνήμη του Γεωργίου Α. Σωτηρίου (1881-1965)

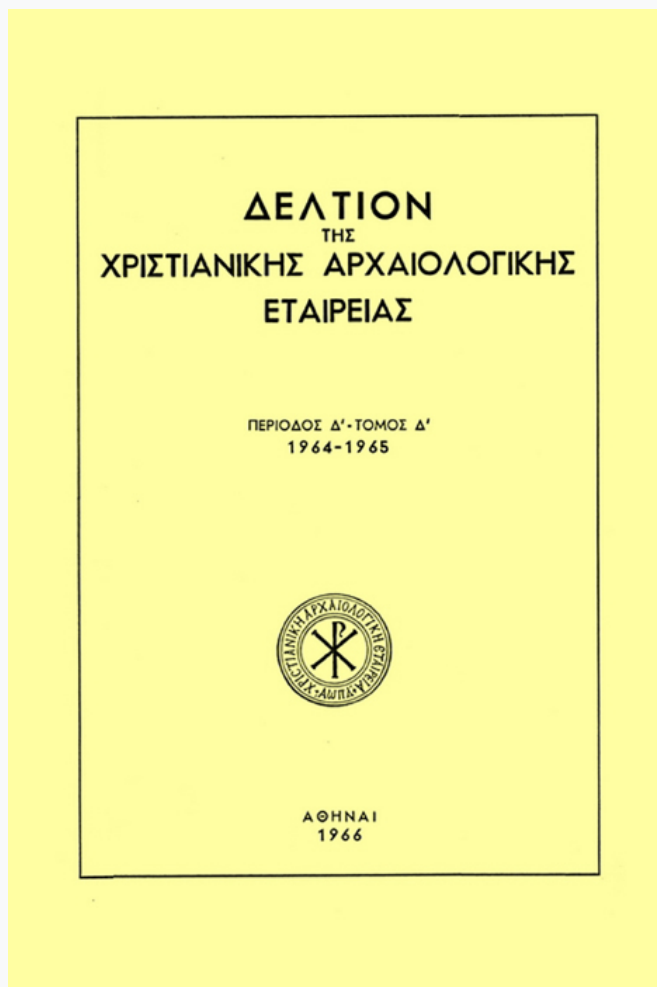

### Εφωλαωμένα πινάκια σε βυζαντινούς ναούς

Arthur H. S. MEGAW

doi: [10.12681/dchae.761](https://doi.org/10.12681/dchae.761)

### Βιβλιογραφική αναφορά:

MEGAW, A. H. S. (1966). Εφωλαωμένα πινάκια σε βυζαντινούς ναούς. *Δελτίον της Χριστιανικής Αρχαιολογικής Εταιρείας*, 4, 145-162. <https://doi.org/10.12681/dchae.761>



# ΔΕΛΤΙΟΝ ΤΗΣ ΧΡΙΣΤΙΑΝΙΚΗΣ ΑΡΧΑΙΟΛΟΓΙΚΗΣ ΕΤΑΙΡΕΙΑΣ

## Glased Bowls in Byzantine Churches

Arthur MEGAW

Δελτίον ΧΑΕ 4 (1964-1965), Περίοδος Δ'. Στη μνήμη του  
Γεωργίου Α. Σωτηρίου (1881-1965) • Σελ. 145-162

ΑΘΗΝΑ 1966

## GLAZED BOWLS IN BYZANTINE CHURCHES

Early excavators of Greek sites set little store by the pottery found in the Byzantine levels<sup>1</sup>. The scholar to whom this volume is dedicated was prominent among those who secured for it the attention it deserves. The material found in his own early excavations<sup>2</sup> and his assembly of a representative collection in the Byzantine Museum in Athens focused attention on the interest of the unpretentious medieval wares found in Greece. It is ultimately to such initiatives as these that we owe the publications on material found by other excavators, at Olynthus<sup>3</sup> and Corinth<sup>4</sup>, as well as the interim reports on the wealth of material from the Athenian Agora, including some dated groups<sup>5</sup>. It was the same scholar who stimulated in the present writer an interest in those glazed bowls which have survived for centuries immured in the walls of Byzantine churches. I offer him here an account of some which I have had opportunities to examine.

Glazed bowls were commonly used to enrich the facades of Greek churches in the eleventh and twelfth centuries, usually as focal ornaments in window tympana. The practice, which spread to Italy,

---

1. Honourable exceptions include the excavators of Sparta: R. M. Dawkins and J. P. Droop, «Byzantine Pottery from Sparta», B.S.A. XVII, 1910-11, p. 23f.

2. On the Areopagus in 1916 ('Αρχ. Δελτ. 2, 1916, p. 136-8), at Thessaloniki in 1917-18 (G. A. and Maria G. Soteriou, 'Η Βασιλική τοῦ ἁγίου Δημητρίου Θεσσαλονίκης, Athens, 1952, p. 237-243) and Ephesus ('Αρχ. Δελτ. 7, 1921-22, p. 188-195).

3. A. Xyngopoulos, in Olynthus V, 1933, p. 285-292.

4. A. Philadelphus, Βυζ. 'Αγγεῖα ἐκ τῶν 'Ανασκαφῶν Παλαιᾶς Κορίνθου, Δελτ. Χριστ. 'Αρχ. 'Εταιρείας I, 1924, p. 22f., followed by the articles of F. O. Waagé and Alison Frantz, and the final publication of C. H. Morgan, Corinth XI: The Byzantine Pottery, 1942. Only thirty of the 1788 items described were found before 1929; the excavations started in 1896.

5. F. O. Waagé, in Hesperia II, 1933, p. 308f; M. Alison Frantz, «Middle Byzantine Pottery in Athens», Hesperia VII, 1938, p. 429f.

was revived after the Latin Occupation, notably at Mistra<sup>1</sup>. In many cases, the bowls have fallen, or have been removed. The significance of those that survive for the chronology of Byzantine pottery has been remarked<sup>2</sup>. On the other hand, as knowledge of this pottery has advanced, the presence of a well-known type has occasionally been used to give precision to the dating of the church it adorns<sup>3</sup>. The subject still awaits a systematic survey. The present contribution is limited to three churches, where facilities for examining the surviving bowls at close quarters were available at the time of my visits. Their humble character will not, I hope, discourage others from examining such as exist in other churches<sup>4</sup>.

There is no external evidence of the building dates of the three churches with which we are concerned. The evidence of their architectural style is as follows:

*Loukisia (Boeotia), Church of Ayios Yeoryios*<sup>5</sup>.

The gable treatment of this little tetraconch building repeats that of the exo-narthex of the Kapnikarea church in Athens, for which a date in the third quarter of the eleventh century is indicated. Its

---

1. G. Millet, *L'école grecque dans l'architecture Byzantine*, Paris 1916, p. 283; Megaw, «The Chronology of Some Middle Byzantine Churches», B.S.A. XXXI, 1931-32, p. 126.

2. Cf. D. Talbot Rice, *Byzantine Glazed Pottery*, Oxford 1930, p. 16.

3. E. g. Megaw, in B.S.A. XXXIII, 1932-33, p. 148f. (Ayia Varvara at Eremos, Mani); Drandakis, in E.E.B.Σ. KE', 1955, p. 49f. (Ayioi Theodoroi near Trypi, Laconia).

4. The following seem particularly worthy of attention; Athens, church of Ayioi Theodoroi:—The greater part of two rather large shallow bowls with horizontal rims and yellow glaze. That in the tympanum of the west gable window has an eagle with filling ornaments covering the whole surface. That in the tympanum of the north gable window is covered with foliate scrollwork.

Areia (Argolis), Ayia Moni:—two Islamic bowls in the south gable with a broad palmette scroll incised round the rim and turquoise glaze. Above the north window of the west wall, a bowl with a bold rosette in white (slip-painted?) on a muddy green ground. Another in the north wall above the porch has a different rosette (reserved in white?) on a greenish-brown ground. Elsewhere the bases only of what appear to have been yellow and purple lustre bowls.

Eremos (Mani), Ayia Varvara:—Three excellent slip-painted bowls which I briefly described in B.S.A. XXXIII, 1932-33, p. 148.

5. Megaw, «The Chronology», op. cit., p. 127 and pl. 27, 3; Orlandos, A.B.M.E. Γ', 1937, p. 166-171.

windows lack the stone surrounds which were increasingly used in the twelfth century. Following these slender indications, Orlandos placed the church in the second half of the eleventh century. Of the twelve bowls immured in this church only one has survived.

*Gastouni (Elis), Church of the Panayia Katholiki*<sup>1</sup>.

Judging from some early features, which in this region might be merely «retardataires», Millet assigned this church to the eleventh century. But the level cornice of the dome and the use of the Greek fret in the ornamental brick-work links this church to the twelfth century group in Argolis. It shares with the latest of these, the church at Merbaka, the manner in which the dentil courses round the window arches are carried down to the bottom of the openings and then extend round the building; also the treatment of the half-arches flanking the south gable window, which likewise extend to the sill. The absence of stone window-surrounds is not by itself an impediment to a late twelfth century date; even at Merbaka, where they reach full elaboration in the apses, they are lacking in the gable windows. The type of tympanum filling used over the east window of the Gastouni church with concentric courses of brick centred on the window arches, is repeated in the Ayia Moni (1143-1149) and in the north gable of the Omorphi Ekklisia, where the window has the stone surround. A date in the second half of the twelfth century is to be preferred. Apart from the seven bowls described below, there were seven more of which nothing has survived.

*Merbaka (Argolis), Church of the Panayia*<sup>2</sup>.

I have elsewhere contested Struck's connection of this church with the convent completed by Bishop Leon before 1143, when he restored the Ayia Moni at Areia as a house of monks. In many points of detail it marks a technical advance on the Areia church. The appearance

---

1. H. Monneret de Villard, *Monitore Tecnico* XVIII, 1912, p. 432, fig. 7; Millet, *op. cit.*, p. 144, 253, 266 and figs. 72, 114 and 141; R. Traquair, in *Journ. Royal. Inst. of British Architects* XXXI, 1923-24, p. 80f; Megaw, «The Chronology», *op. cit.*, p. 111, 118 and 127, pl. 29, 2 and 3.

2. A. Struck, *Ath. Mitt.* XXXIV, 1909, p. 201-210; Millet, *op. cit.*, p. 57 with note 4 and figs. 84, 118, 119 and 129; Megaw, «The Chronology», *op. cit.*, p. 95, 114, 118 and 123.

at Merbaka of the cut-brick frieze of the later «disepsilon» type (lacking at the other church) and its greater elaboration of the stone dressings, notably in the east windows, speak for a later date. In the distribution of the glazed bowls also the Merbaka church marks an advance. In the twelfth century they tended to multiply, but only here do they spread from the decoration of windows to adorn the wall surfaces between them. There were 49 in all, of which identifiable remains of 22 have survived. Millet seems to have appreciated that Merbaka was later than Leon's church at Areia but still referred to it as mid-twelfth century. A date closer to 1200 seems preferable.

How far does the study of the bowls immured in these churches and described in the catalogue below confirm or conflict with the above estimates of their building dates?

*Loukisia.* The Loukisia bowl, no. 1 (fig. 1), corresponds in form with examples from refuse-dumps of Comnene date in the area of the Great Palace<sup>1</sup>, with others of Corinthian fabric assigned to the first half of the twelfth century<sup>2</sup> and with one found in Athens in a closed deposit of that period<sup>3</sup>. Its decoration puts it in an early class of the fine sgraffito wares in which both plates and bowls have a central medallion filled with elaborately involuted arabesques based on the half-palmette. Together with comparable fragments from Istanbul<sup>4</sup> and Sparta<sup>5</sup>, it can be dated to the reign of Alexius I (1081 - 1118) by the presence of an imported plate with a very similar medallion in a well group found at Corinth which contained three coins of that Emperor<sup>6</sup>. Confirmation is provided by the base of a shallow bowl of light red clay found in a pit in the Agora at Athens, again with coins of Alexius I; for the background of the seated lion which occupies its medal-

---

1. R. B. K. Stevenson, «The Pottery», in *The Great Palace of the Byzantine Emperors*, First Report, 1947, pl. 20, 32 and pl. 23, 8.

2. E. g. Morgan, *op. cit.*, n° 997, fig. 95D.

3. Alison Frantz, *op. cit.*, p. 466, fig. 32, n° A31.

4. Second Report on the Excavations of the Hippodrome, 1929, p. 25, fig. 16; Rice, *op. cit.*, pl. XIII, centre.

5. Dawkins and Droop, *op. cit.*, pl. XV, 16.

6. Morgan, *op. cit.*, n° 1137, fig. 198; on the well group, p. 135 and 175f. In addition to the medallion it has a band of debased Kufic below the rim. Corinthian potters produced simplified versions of this ornament both on contemporary bowls similar in form to the Loukisia bowl and on plates (e. g. *ibid.* nos. 992 and 997, figs. 23 A and B).

lion is filled with similar, but better executed half-palmette arabesques<sup>1</sup>.

The survival of the Loukisia bowl thus makes it possible to control the scant architectural indications of the building date of the church it

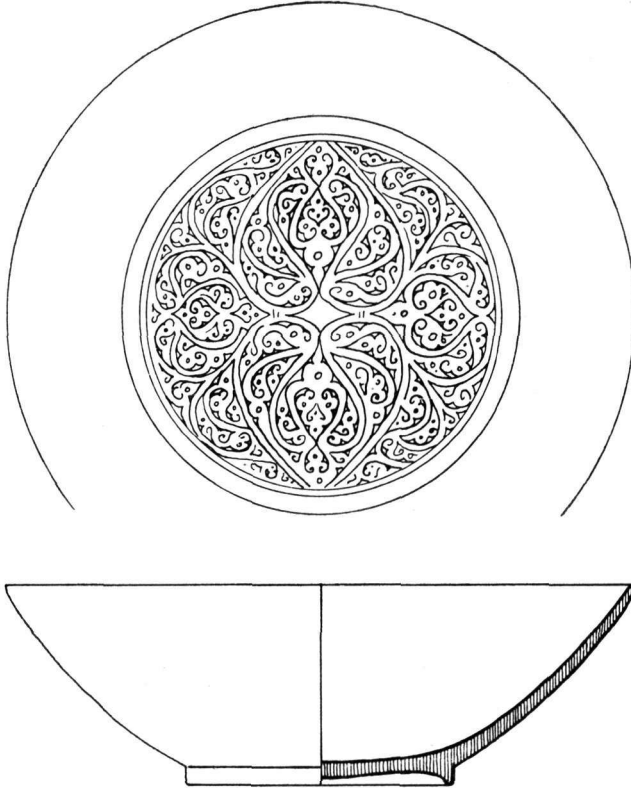

Fig. 1. Loukisia. Sgraffito Bowl (no. 1). Scale 1 : 2.

adorned. These require a date in the second half of the twelfth century; the bowl requires one near its close, certainly not earlier than 1080.

*Gastouni.* The sgraffito bowls with dark green glaze in the Gastouni church bring us to a later phase of this class of decoration, which was accompanied by developments in form and glaze. The horizontal rim of the two bird plates nos. 2 and 3 (fig. 2) was in this ware a development of the mid-twelfth century, to judge by examples from Athens<sup>2</sup>,

1. Alison Frantz, *op. cit.*, p. 461, fig. 26 (C4).

2. *Ibid.* p. 466, fig. 33 (A45) from debris thrown into a cistern following a fire in the reign of Manuel I.

and Corinth<sup>1</sup>; it continued into the thirteenth<sup>2</sup>. The form of the three small bowls nos. 4 to 6 (fig. 3) is unusual. The vertical inner rim seems too high to be merely the flange for a lid and the manner in which it

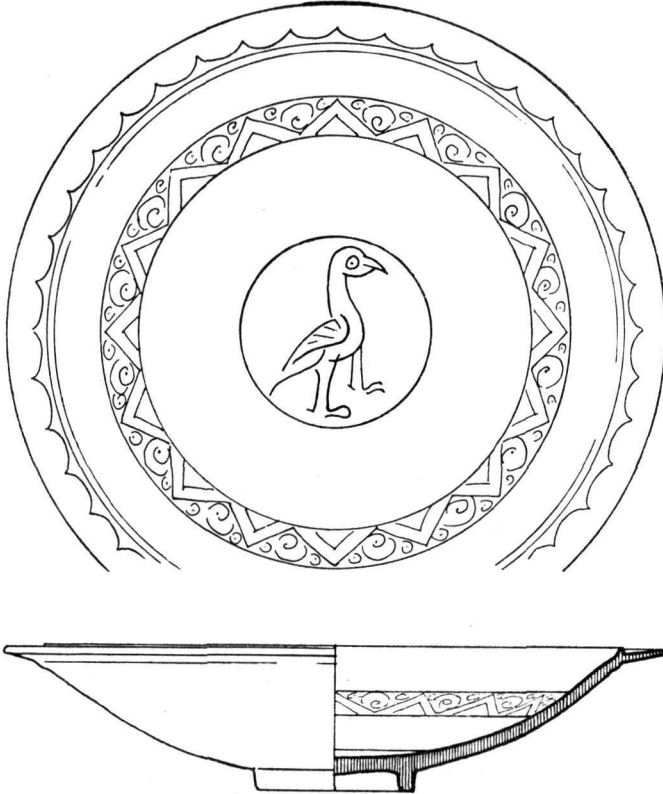

Fig. 2. Gastouni. Sgraffito Plate (no. 2). Scale 1:3.

isolates the bowl proper, which is very small and undecorated, from the decorated flaring rim suggests it may be a type of thymiaterion. The form is known in the Proto-majolica ware, which was current in the thirteenth century but probably made already in the late twelfth<sup>3</sup>. It occurs also among the plain glazed bowls in the Merbaka church (no. 25, fig. 7).

Relatively late also is the form of the deep bowl no. 7 (fig. 4). In

1. Morgan, *op. cit.*, n° 1185, fig. 103, i (mid-twelfth century sgraffito) and n° 1718, fig. 140, c (incised ware).

2. *Ibid.* n° 1424, fig. 119, A (thirteenth century painted sgraffito).

3. E. g. *ibid.* n° 840, fig. 83, D. On the date, *ibid.* p. 107.



the large twelfth-century series from Corinth it does not occur. At Constantinople the almost vertical or in-curving rim appears rarely among the bowls from the Great Palace rubbish-dumps included in the late

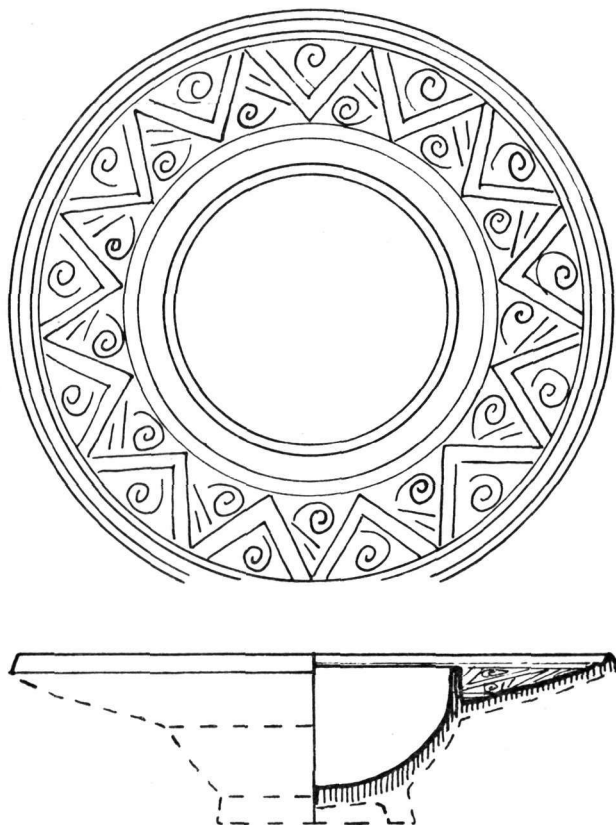

Fig. 3. Gastouni. Sgraffito Bowi (no. 4). Scale 1 : 2.

Comnene stage<sup>1</sup>, but is characteristic of the Palaeologue period<sup>2</sup>. At Thessaloniki incised sgraffito bowls with almost vertical rims assigned to the late twelfth or early thirteenth century<sup>3</sup> marked the beginning of a long vogue for the deep form<sup>4</sup>. The earliest of the innumerable

1. Stevenson, *op. cit.*, p. 54-55 and pl. 18, 7-8, pl. 20, 19.

2. *Ibid.* pl. 25, 25.

3. G. A. and M. G. Soteriou, *Ἡ Βασιλικὴ τοῦ ἁγίου Δημητρίου*, *op. cit.*, pl. 98B.

4. Cf. Xyngopoulos, in *Olynthus V*, pl. 207, 19 and p. 291 for the date (fourteenth century) and attribution to Thessaloniki.

deep bowls made in Cyprus cannot, on present evidence, be earlier than the thirteenth century<sup>1</sup>, while at Al Mina on the Syrian coast the form of our Gastouni bowl, including the distinctive lip turned-down on the

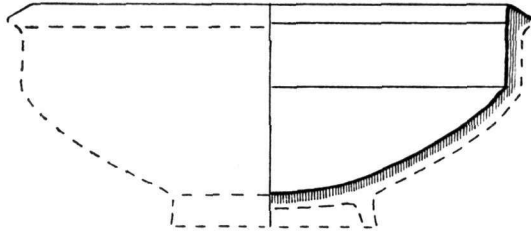

Fig. 4. Gastouni. Green glaze Bowl (no. 7). Scale 1 : 3.

outside, was one of those adopted for the painted sgraffito ware made there during the Crusading period, but probably not before 1200<sup>2</sup>.

As to the dark green glaze, at Corinth it first appears in connection with sgraffito decoration in the developed style of the mid-twelfth century, and then only rarely<sup>3</sup>; it is commoner in the class assigned to the late twelfth and thirteenth centuries<sup>4</sup>. It is also used on incised-sgraffito plates of the free style assigned to the reign of Manuel I and his immediate successors<sup>5</sup>. Likewise in the stratified cistern deposits in Athens: the green glaze first appears on two sgraffito bowls from the layer accumulated after a fire in the reign of Manuel I<sup>6</sup>.

The cursory ornamentation on the Gastouni pieces is equally removed from the intricate designs in favour in the late eleventh and early twelfth century. The gouge employed in the incised technique that came into vogue in the mid-twelfth century was used neither on the plates nor on the little bowls; but the pattern on the rims of the latter provides a link with this later technique. For an analogous pattern on the flat rim of a green glazed bowl from Pergamon is accompanied in the centre by a zig-zag band and lines cut with the gouge<sup>7</sup>.

1. Cf. A. I. Dikigoropoulos and A. H. S. Megaw, « Early Glazed Pottery from Polis », Report Dept. Antiq. Cyprus 1940-48, p. 78-93.

2. Lane in *Archaeologia* 87, 1937, p. 46 and fig. 8.

3. Morgan, *op. cit.*, p. 128 (e. g. n° 1188).

4. *Ibid.* nos. 1295, 1302 and 1363.

5. *Ibid.* nos. 1516, 1521 and 1603; but on only one example of the somewhat earlier medallion style (n° 1433).

6. Alison Frantz, *op. cit.*, nos. A36 and A38.

7. Berlin, n° 2196 (O. Wulff, *Beschreibung der Bildwerke* III, ii, pl.

All these indications agree and they require that the manufacture of this Gastouni group of bowls be placed well into the second half of the twelfth century. They are united, despite their different forms, by identity of clay and glaze and they doubtless represent a contemporary ware readily available in the locality at the time the church was built. Their position high above ground-level would warrant the use of rather common-place vessels.

The prominent position over the rather low east window was another matter and here was set the Proto-majolica bowl, no. 8, of which only the base is preserved. Wherever it was made, this ware would have been a novelty in Gastouni even in the last decades of the twelfth century, for though its first appearance at Corinth may date from the late twelfth century<sup>1</sup> it is better attested in the thirteenth<sup>2</sup>. Since only the base remained in position I was able to confirm that this bowl was not a later insertion: it was set in the mortar with which the surrounding brick-work was constructed. The survival of this painted base in its original position makes it difficult to put the building date earlier than the last quarter of the twelfth century, and that would not be too late for the other bowls. Their combined evidence provides welcome support for the relatively late dating indicated by a few advanced architectural features. Without this independent evidence the undeveloped type of plan and the absence of stone window-surrounds would have weighed against it.

*Merbaka.* The series of eleven Proto-majolica bowls in the Merbaka church (nos. 9 to 20), exactly half of all those preserved, point to the erection of that church when the ware was no longer uncommon. Comparable bowls with a simple cross-hatched medallion in the base have been found at Atlit<sup>3</sup>, and, in combination with herring-bone border and loops on the rim, on bowls identical with our nos. 9 to 14 (fig. 5), at Hama<sup>4</sup> and Corinth<sup>5</sup>. At this latter site the gridiron with a dot of

XXVII). The substitution of the spirals by spots of paint in the painted-incised-sgraffito manner indicates a date possibly as late as the thirteenth century.

1. Morgan, op. cit., p. 107.

2. At Atlit during the Crusader occupation (1217-91); coins of the late twelfth century were also present (C. N. Johns, « Medieval Slip-Ware from Pilgrims Castle », Quart. Dept. Antiq. Palestine III, 1934, p. 137); at Corinth with coins of Villehardouin (Morgan, op. cit., p. 294 under no 1293).

3. Johns, op. cit., p. 138. Matching our nos 16 (fig. 7) and 17.

4. Hama, IV2, 1957, p. 131, fig. 402.

5. Philadelphus, op. cit., p. 24, no I; Waagé, in Hesperia III, p. 131, fig. 3, I; Morgan, op. cit., nos 819-823 and pl. XXXVI, b.

colour in each square, as on our no. 18, also occurs<sup>1</sup>. The medallion with a quatrefoil motif similar to our no. 19 (fig. 6) is used on examples of this ware at Corinth<sup>2</sup> and it is also represented at Al Mina<sup>3</sup>. The

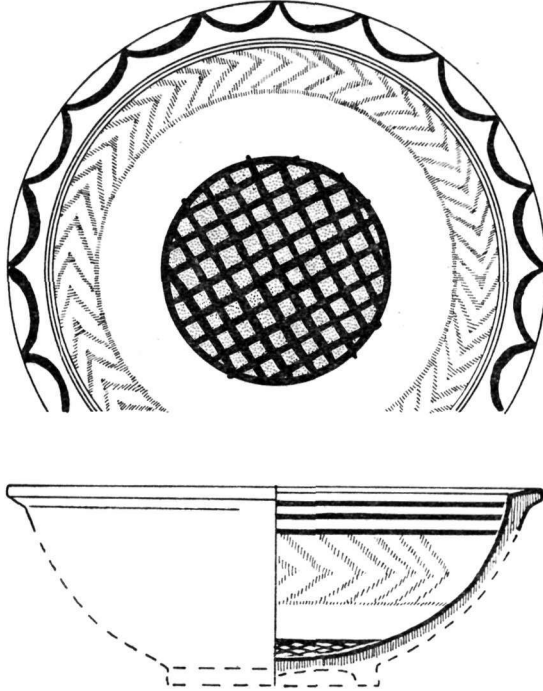

Fig. 5. Merbaka. Proto-majolica Bowl (no. 9). Scale 1:2.

cross-hatched bud of our fragment no. 20 also occurs wherever the ware is found<sup>4</sup>. It is noteworthy that the decoration in all cases is simple. It may be that the more ambitious representations of beasts, fish, ships and human figures were a later development, for one of these figured bowls is built into a church which there is good reason to place in the second half of the thirteenth century<sup>5</sup>.

1. Philadelphus, *op. cit.*, p. 23, n° 2; Morgan, *op. cit.*, n° 832.

2. Waagé, in *Hesperia* III, p. 133, fig. 5, 9; Morgan, *op. cit.*, nos 847-851 and pl. XXXVI, d.

3. Lane, in *Archaeologia* 87, pl. XXVII, 2.

4. E.g. Atlit: Johns, *op. cit.*, pl. LI, 3; and Corinth: Waagé, in *Hesperia* III, p. 132, fig. 5, n° 13; Morgan, *op. cit.*, n° 842.

5. Drandakis, in *E.E.B.Σ. KE'*, 1955, p. 48, fig. 8. The base of another figured bowl survives above the door of the Omorphi Ekklesia in Aegina (1282).

No less relevant to the chronology of the simple class of Proto-majolica, if not also to the location of its manufacture, is the fact that the motifs employed are found in Byzantine wares of the twelfth

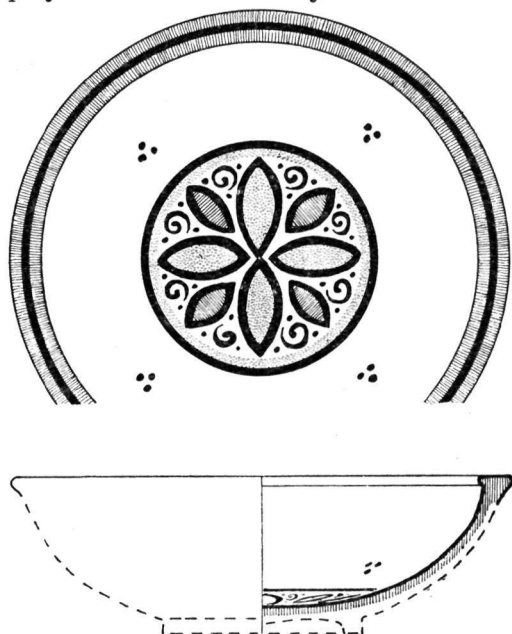

Fig. 6. Merbaka. Proto-majolica Bowl (no. 19). Scale 1 : 2.

century. The simple cross-hatched medallion is found both in the green and brown painted ware<sup>1</sup> and in the incised technique<sup>2</sup>. The herring-bone border occurs in the latter<sup>3</sup> and also on slip-painted bowls<sup>4</sup>. The cross-hatched buds are found in the green and brown painted ware<sup>5</sup>, as are the quatrefoil and the rosette<sup>6</sup>. The border of loops on the rim repeats a feature of the Gastouni plates (fig. 2). Finally the gridiron with dots or spirals in each square is very common on incised bowls<sup>7</sup>

1. Athens: Waagé, in *Hesperia* II, p. 324, fig. 18, 1; Corinth: Morgan, *op. cit.*, n° 448.

2. E. g. Berlin n° 2136, from Pergamon: Wulff, *Beschreibung der Bildwerke* III, ii, p. 115, pl. XXV.

3. E. g. Berlin n° 2115, from Constantinople: *ibid.* p. 113 and pl. XXIV.

4. E. g. at Corinth: Morgan, *op. cit.*, nos 711 and 712.

5. E. g. at Athens: Alison Frantz, *op. cit.*, nos A6 and A22.

6. E. g. at Corinth: Morgan, *op. cit.*, nos 482 and 493.

7. E. g. at Sparta: B.S.A. XVII, 1910-11, pl. XVII, 40; Athens: *Hesperia*

and is found also at Corinth in the painted technique which imitates Islamic lustre-ware<sup>1</sup>. This repetition of twelfth-century Byzantine motifs on the Proto-majolica bowls with simple decoration seems to confirm their relatively early date. The use of this simple type to embellish the Merbaka church does not therefore conflict with the dating around A.D. 1200 which is indicated by its architecture.

All the lead-glazed bowls in the Merbaka church, with the exception of the base no. 27, bearing traces of a sgraffito design, are unornamented save for a few concentric circles in one or two cases. The variety of their forms and glazes is noteworthy. The simple bowls nos. 23 and 26 (fig. 7) are close to those of the Proto-majolica ware in form. On no. 23 the slightly turned-down lip recalls that on the larger Gastouni bowl (fig. 4) but is less pronounced. No. 25 (fig. 7) repeats the unusual vertical inner rim of the three small Gastouni bowls (fig. 3). Nos. 21 and 28 (fig. 7), the one of rounded and the other of angular form, share the rather deep proportion that is uncommon before the end of the twelfth century and the flaring rim that came into its own in the thirteenth<sup>2</sup>.

The variety of the glazes is even more striking. Apart from the familiar yellow (nos. 23 and 24), green (no. 29) and colourless glazes (nos. 21 and 22 over a creamy slip), the rare orange glaze<sup>3</sup> is used for

---

II, p. 314, fig. 10d and Alison Frantz, *op. cit.*, no A53 (mid-twelfth century fire deposit); Corinth: Morgan, *op. cit.*, no 1465 (incised dots) and no 1468.

1. *Ibid.* no 595. I leave for others to consider whether these relationships between the simplest type of Proto-majolica and Byzantine pottery signify direct interdependence or common borrowings from Islamic wares. But the fact that these relationships exist supports the view that Proto-majolica was first made in the Levant (cf. Lane, in *Archaeologia* 87, p. 56-58). The abnormal shiny yellow glaze of no 17 and the abnormal orange clay of no 18 are suggestive of experimentation.

2. In the Proto-majolica ware: Johns, *op. cit.*, p. 138, fig. I, a and b; Lane, in *Archaeologia* 87, p. 44, fig. 7, B, C, and E. In the painted sgraffito ware made at Al Mina ca. 1200-1268: *ibid.* p. 47, fig. 8, A and B. The angular form of our no 28 approximates to that of a handsome incised-sgraffito bowl from the Great Palace assigned to the late Comnene stage: Stevenson, *op. cit.*, pl. 20, 10.

3. At Corinth orange glaze is reported only on an exterior of a cup fragment painted in the polychrome style: Morgan, *op. cit.*, no 392. It is found in Cyprus on a thirteenth century plain sgraffito bowl in the Z. D. Perides collection (Report Dept. Antiq. Cyprus 1937-39, p. 4 and pl. IV, 1) and on an incised-sgraffito fragment from the Polis area, which is closer to Byzantine twelfth-century forms (Report Dept. Antiq. Cyprus 1940-48, p. 88, no 9).

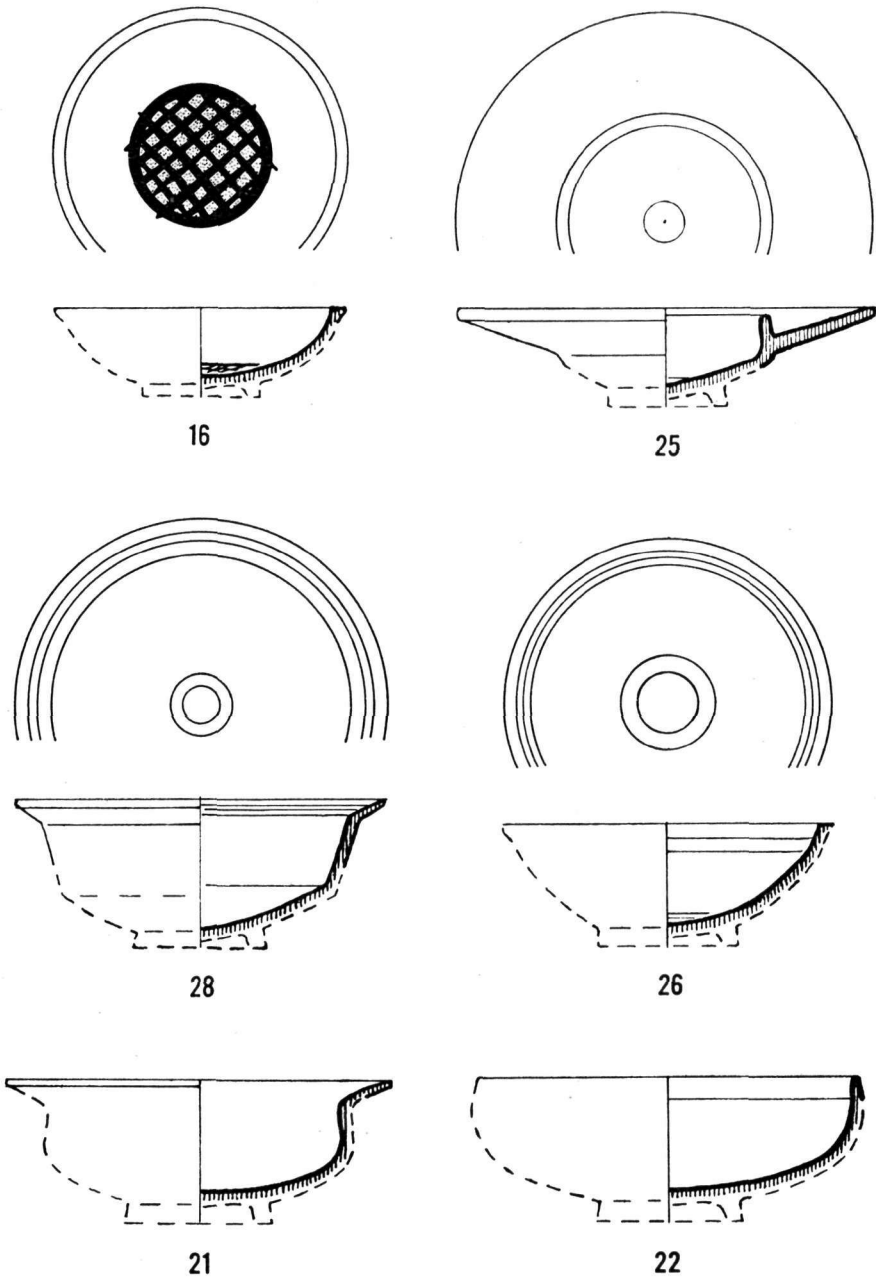

Fig. 7. Merbaka. Proto-majolica (no. 16) and plain glazed Bowls. Scale 1 : 3.

no less than three pieces (nos. 25 to 27), while no. 28 has the equally uncommon purple glaze<sup>1</sup>. There remain the two plain bowls with turquoise glaze (nos. 30-31), which are doubtless imported Islamic pieces. They may be regarded as poor relations of the type of bowl with carved decoration and monochrome glaze which was made in both Persia and Egypt in the mid-twelfth century, and which occasionally reached Greece<sup>2</sup>. Plain bowls of this kind are known to have been made in Syria from the late twelfth century<sup>3</sup>. Like the other plain glazed bowls they cannot be closely dated, but their presence in the walls of the Merbaka church does not seem inconsistent with the date around 1200 indicated for its erection by its architectural style.

On the other hand both the plain and the painted bowls would admit of a somewhat later dating. It does not, however, seem likely that the conditions which followed the capture of Nauplia and Argos by Geoffrey de Villehardouin in 1213 would have permitted the erection of a church of such careful construction and essentially Byzantine style.

#### C A T A L O G U E

##### 1. Loukisia. West gable, south half-arch. Fig. 1.

Sgraffito bowl. Ht. 0.054 m. (int. 0.047). Diam. 0.171 m.

Fine brick-red clay. Slip all over, but much has flaked off leaving glaze in relief on incisions. In a central medallion symmetrical arabesques of stylised half-palmettes. Colourless lead glaze. Much of the rim and part of the medallion missing. Now in the Byzantine Museum (no. 1809)<sup>4</sup>.

---

1. At Corinth only two examples are reported: a plate (Morgan, op. cit., no 786) and a sgraffito bowl (ibid. no 1254) both assigned to the mid-twelfth century.

2. Such I take to be the bowl found in the excavation of the church by the Areopagus (Soteriou, 'Αρχ. Δελτ., 1916, p. 137 and fig. 13). Such may also be the two somewhat similarly ornamented turquoise bowls in Ayia Moni (see above p. 146 note 4).

3. Cf. Hama, IV2, 1957, p. 150.

4. I was thus able to handle the bowl at leisure and make an accurate drawing of the design (partly restored on fig. 1). In the other cases, (fig. 2-7) conditions of working at the top of precarious ladders imposed a diagrammatic character on my drawings, and explain some gaps in my notes. Where the bowls were complete it was in any case impossible to observe either the clay or the treatment of the exterior.



## 2-3. Gastouni. South gable, in the half-arches. Fig. 2.

Two identical Sgraffito plates. Ht. 0.057 m. Diam. 0.265 m.

Hard buff clay. Slip all over. Bird in a central circle; border of triangles filled-out with spirals; loops on rim. Dark green lead glaze all over including base, visible on the right-hand plate which is much damaged.

## 4-6. Gastouni. South gable, in the window tympanum. Fig. 3.

Three identical Sgraffito bowls. Int. ht. 0.035 m. Diam. 0.165 m.

Clay, slip and green glaze as no. 2, except that the clay of the centre bowl is reddish. In one the inner, vertical lip rises above the height of the flaring rim. On the latter a border of spiral-filled triangles divided by zig-zag band. Dark green glaze.

## 7. Gastouni. South gable, above no. 2. Fig. 4.

Deep plain glazed bowl. Int. ht. 0.075 m. Diam. 0.213 m.

Clay, slip and glaze as no. 2. Unornamented except for a line on the rim. Dark green glaze.

## 8. Gastouni. In tympanum of apse window.

Base of Proto-majolica bowl. Estimated int. ht. 0.05 m. Est. diam. 0.17 m.

Porous buff clay. Very thin white tin-enamel glaze. Cross-hatching over-painted in yellow-brown, probably limited to a central medallion.

## 9-14. Merbaka. Above south gable window. Fig. 5.

Five identical Proto-majolica bowls. Int. ht. 0.045 to 0.05 m. Diam. 0.145 m.

Pinkish buff clay. Thin white tin-enamel glaze with matt surface. Over-painted dull yellow medallion in base, cross-hatched and outlined in purple-black; herring-bone border in blue below group of three purple-black lines at rim; purple-black loops on flat top of rim.

## 15. Merbaka. Same position as nos. 9-14.

Similar Proto-majolica bowl.

In place of herring-bone border a plain blue band. In the yellow medallion the cross-hatching is limited to a smaller central circle, separately outlined.

16. Merbaka. Over the south door of Narthex. Fig. 7.  
 Small Proto-majolica bowl. Int. ht. 0.025 m. Diam. 0.115 m.  
 The right one of a pair. Clay, glaze and over-painted central medallion as no. 9.
17. Merbaka. Same position as no. 16.  
 Similar Proto-majolica bowl.  
 The left one of the pair. Clay not seen. Shiny yellow glaze.  
 Smaller medallion.
18. Merbaka. East wall, between main apse and that of Diaconicon.  
 Base of Proto-majolica bowl. Est. int. ht. 0.05 m. Est. diam. 0.165 m.  
 Yellowish red clay. Glaze as no. 9. Gridiron over-painted in blue covering the whole of the surviving fragment; in each square a brown-purple dot.
19. Merbaka. Over Diaconicon window. Fig. 6.  
 Proto-majolica bowl. Int. ht. 0.04 m. Diam. 0.145 m.  
 Clay and glaze as no. 9. Over-painted decoration: within black and dull yellow circles a rosette of four large dull yellow ovals, with four smaller grey-blue ovals between them, all outlined in black; black spirals and dots in the spandrels; groups of three black dots on the sides; on the flat top of the rim, a black line on grey-blue.
20. Merbaka. Over Prothesis window.  
 Base of Proto-majolica bowl.  
 Hard clay, red in the core, pinkish buff on the surface; thin tin-enamel glaze showing grey. Over-painted scroll-work ending in cross-hatched buds, all in black.
21. Merbaka. Over main apse window. Fig. 7.  
 Plain glazed bowl. Int. ht. 0.45 m. Diam. 0.152 m.  
 Red clay. Lead glaze, cream-coloured over slip.
22. Merbaka. Over Diaconicon window. Fig. 7.  
 Plain glazed bowl. Int. ht. 0.045 m. Diam. 0.152 m.  
 Red clay. Lead glaze, cream-coloured over slip.
23. Merbaka. South-east face of Diaconicon apse.  
 Plain glazed bowl. Int. ht. 0.045 m. Diam. 0.152 m.  
 Form as Fig. 7 no. 26 but steeper rim with flat lip slightly turned down on the outside. Yellow lead glaze over slip.

24. Merbaka. Over Prothesis window.  
Base of glazed bowl.  
Red clay. Yellow lead glaze over slip. Concentric circles in the base drawn with a fine point.
25. Merbaka. North-east face of Diaconicon apse. Fig. 7.  
Small plain glazed bowl. Int. ht. 0.28 m. Diam. 0.165 m. Diam. within inner vertical rim 0.075 m.  
Red clay. Orange lead glaze over slip. Circle drawn with a fine point in the rather pointed bottom of the bowl.
26. Merbaka. South-east face of main apse. Fig. 7.  
Small plain glazed bowl. Int. ht. 0.038 m. Diam. 0.133 m.  
Red clay. Orange lead glaze over slip. Two concentric circles in the bottom and pair of lines below the rim drawn with a fine point.
27. Merbaka. North-east face of main apse.  
Base and part of side of Sgraffito bowl.  
Red clay. Orange lead glaze over slip. Sparse irregular lines drawn with a fine point without any intelligible design on the preserved fragment. Marks left by the use of a firing stilt in the form of a tripod<sup>1</sup>.
28. Merbaka. South-east face of main apse. Fig. 7.  
Plain glazed bowl. Int. ht. 0.05 m. Diam. 0.145 m.  
Red clay. Purple glaze over slip. Two small concentric circles in the bottom and pair of lines on flaring rim, drawn with a fine point.
29. Merbaka. North-east face of Prothesis apse.  
Plain glazed bowl. Int. ht. 0.045 m. Diam. 0.152 m.  
Simple form similar to no. 22. Grey-green glaze over slip. Concentric circles drawn with a fine point.

---

1. The tripods seem not to have been used in the twelfth century Corinthian factories, which apparently did not recover after the sack of the city by Roger of Sicily in 1147. If, as Morgan claims (op. cit., p. 23), they were not used by Byzantine potters before the fourteenth century, our bowl must be either an import or a later insertion.

30-31. Merbaka. Above main apse window, to right and left of no. 21.

Two identical plain glazed bowls. Int. ht. 0.045 m. Diam. 0.145 m.

Form as no. 19, but deeper. Pinkish buff clay. Alkaline (?) turquoise glaze.

A. H. S. MEGAW