

## Mediterranean Marine Science

---

Vol 10, No 2 (2009)

---



**The presence of the Indo-Pacific symbiont-bearing foraminifer *Amphistegina lobifera* in Greek coastal ecosystems (Aegean Sea, Eastern Mediterranean)**

*M.V. TRIANTAPHYLLOU, O. KOUKOUSIOURA, M.D. DIMIZA*

doi: [10.12681/mms.111](https://doi.org/10.12681/mms.111)

---

### To cite this article:

TRIANANTAPHYLLOU, M., KOUKOUSIOURA, O., & DIMIZA, M. (2009). The presence of the Indo-Pacific symbiont-bearing foraminifer *Amphistegina lobifera* in Greek coastal ecosystems (Aegean Sea, Eastern Mediterranean). *Mediterranean Marine Science*, 10(2), 73–86. <https://doi.org/10.12681/mms.111>

**Mediterranean Marine Science**  
Volume 10/2, 2009, 73-85

**The presence of the Indo-Pacific symbiont-bearing foraminifer *Amphistegina lobifera* in Greek coastal ecosystems (Aegean Sea, Eastern Mediterranean)**

**M.V. TRIANTAPHYLLOU, O. KOUKOUSIOURA and M.D. DIMIZA**

University of Athens, Faculty of Geology & Geoenvironment,  
Dept. of Historical Geology-Paleontology,  
Panepistimiopolis 15784, Athens, Greece

e-mail: mtriant@geol.uoa.gr

---

**Abstract**

*During the last decades, hundreds of species of Indo-Pacific origin from the Red Sea have traversed the Suez Canal and settled in the Eastern Mediterranean. Nowadays, *Amphistegina lobifera* Larsen, the most common epiphytic, symbiont-bearing large foraminifer, is known to be a successful immigrant that is widely distributed in the coastal ecosystems of the Eastern Mediterranean Sea. In this study, we provide additional sites of occurrences on distributional range and settlement of *A. lobifera* in the Greek coastal ecosystems. The high relative abundances recorded are the result of very successful inhabitation of this species in the Aegean ecosystems and suggest that it has become significant part of the epiphytic foraminiferal fauna*

**Keywords:** *Amphistegina lobifera*; benthic foraminifers; Lessepsian immigrants; Aegean Sea; Greece.

---

**Introduction**

A large number of invaders of the Red Sea foraminifer species have been introduced into the Eastern Mediterranean, migrating through the Suez Canal (HYAMS *et al.*, 2002; ZENETOS *et al.*, 2005, 2008; STREFTARIS & ZENETOS, 2006; HYAMS-KAPHZAN *et al.*, 2008; LANGER, 2008a; MERIÇ *et al.*, 2008). Among these Lessepsian species, *Amphistegina lobifera* Larsen is the most abundant (e.g. CHERIF, 1970; AVŞAR, 1997; HOLLAUS &

HOTTINGER, 1997; LANGER & HOTTINGER, 2000; HYAMS *et al.*, 2002; TRIANTAPHYLLOU *et al.*, 2005; KOUKOUSIOURA *et al.*, 2006; GRUBER *et al.*, 2007; LANGER, 2008a; MERIÇ, *et al.*, 2008). However, whether all Mediterranean amphisteginids are true Lessepsian migrants or of Atlantic origin remains still an open question (LANGER, 2008a).

*A. lobifera* is an oligotrophic large foraminifer that bears diatom symbionts worldwide (REISS & HOTTINGER, 1984; HALLOCK, 1988; LANGER &

HOTTINGER, 2000). Furthermore, it has a fossil record of roughly 50 million years (LOEBLICH & TAPPAN, 1988) and is known to have been a major carbonate producing foraminifera of tropical carbonate shelf sediments during that time (LANGER, 2008b). *A. lobifera* lives predominantly on hard and phytal substrates at low to mid depth in tropical and subtropical seas (HANSEN & BUCHARDT, 1977; HALLOCK, 1984; HOHENEGGER, 1994; HOHENEGGER, 1996; HALLOCK, 1999; HOHENEGGER *et al.*, 1999; RENEMA & TROELSTRA, 2001) and limited experimental evidence suggest that it prefers mid to high light conditions (HALLOCK, 1981).

The Aegean Sea, with the geographical distribution of the various island chains, irregular bottom topography, river outflows from the mainland, as well as the high seasonality in sea surface temperatures, solar radiation, and surface water circulation, represents an important field area for study of modern foraminiferal assemblages. Already, previous studies (TRIANTAPHYLLOU *et al.*, 2005; KOUKOUSIOURA *et al.*, 2006) have used benthic foraminiferal distribution patterns as proxies of anthropogenic perturbation on the natural composition of Aegean coastal ecosystems.

In the present paper we provide additional data on the distributional range of *Amphistegina*, so as to understand its role as an immigrant species in the coastal ecosystems of the Aegean Sea.

## Material and Methods

Algal samples were collected (Fig. 1, Table 1) during several sampling periods between 2001 and 2009 in the coastal ecosystems of southern Aegean Sea (Falasarna and Chrissi), central Aegean Sea (Porto Heli, Mavro Lithari, Vravron, Kalamos, Andros

- Korthi and Kastro gulfs) and northern Aegean Sea (Katerini, N. Kallikratia and Avdira). Samples consisting of red (*Jania*, *Amphiroa* and *Corallina*), brown (*Halopteris* and *Padina*) and green algae (*Enteromorpha*), were collected by diving (sampled depths varying between 0.2-3m). Algal samples were carefully cut above the sediment surface to avoid contamination by sediment-dwelling species. Sample location, date of collection and relevant temperature and salinity data are presented in Table 1.

Samples were stored in high-walled plastic bowls and stained with an ethanol-Rose Bengal solution to distinguish between living (stained) and dead (unstained) foraminifera (WALTON, 1952; MURRAY & BOWSER, 2000). In the laboratory, the algal samples were sieved through the >63  $\mu$ m size fraction and dried at 60°C. At least 300 living foraminifera were separated from the micropaleontological samples, picked under a Leica S4E stereozoom binocular microscope and identified following the generic classification of LOEBLICH & TAPPAN (1988).

Living specimens of *A. lobifera* were also examined using a Jeol JSM 6360 Scanning Electron Microscope (SEM), (University of Athens, Department of Historical Geology and Palaeontology), in order to observe external and internal test morphological details. The specimens for SEM investigations were rinsed in distilled water, dried in a desiccator, attached to a copper electron microscope stub using a double-sided adhesive tape and coated with gold.

Hierarchical Q-mode cluster analysis (Ward's method and Euclidean distances as a similarity index) was used to estimate similarities in species composition between the sampling sites. Analysis was applied to 12 genera that exceeded 5% of the total assemblage in at least one sample. Hierarchi-

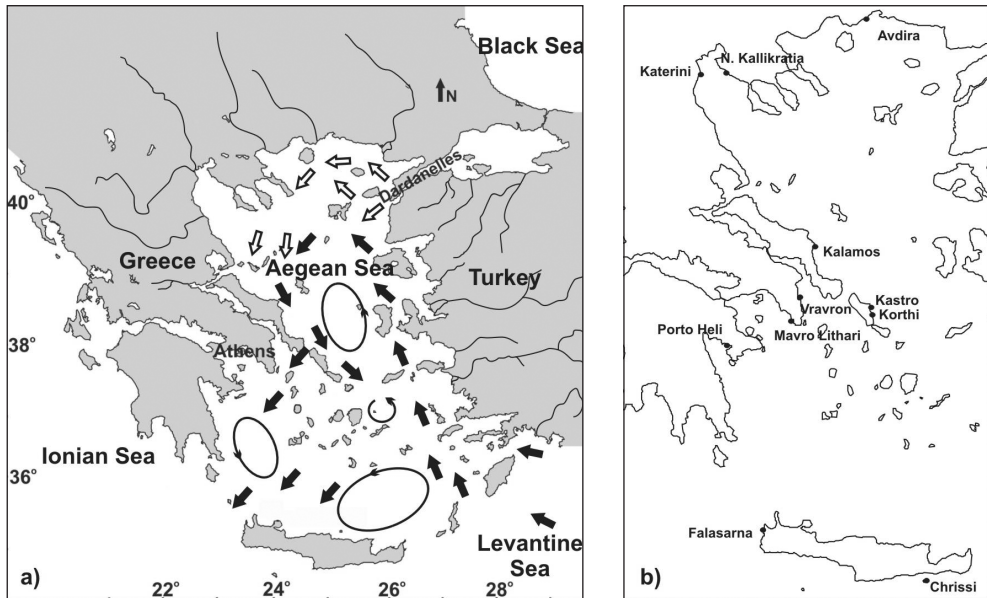

**Fig. 1:** a) Location of the study area in the Aegean Sea and principal circulation patterns of the surface waters, in winter (open arrows) and summer (closed arrows). Arrowed ovals denote cyclones (based on data from Lacombe & Tchernia, 1972; Theocharis & Georgopoulos, 1993; Poulos *et al.*, 1997). b) Locations of sampling sites.

**Table 1**  
**Location data and relative abundances of *A. lobifera* (source for the mean monthly temperature and salinity: NODC (Levitus) World Ocean Atlas Data <http://www.cdc.noaa.gov>).**

Site	Latitude	Longitude	Date of collection	Water depth (m)	mean monthly Temperature (°C)	mean monthly Salinity (‰)	<i>Amphistegina lobifera</i> (%)
Chrissi	34.58	25.39	7/06	0-3	24.45	39.03	42.5
Falasarna	35.29	23.34	7/06	0-3	24.16	38.86	26.5
Porto Heli	37.27	23.06	9/07	0-3	23.05	38.40	32.0
Mavro Lithari	37.43	23.56	10/06	0-3	21.07	38.51	34.0
Vravron	37.56	24.03	5/06	0-3	18.26	38.38	55.5
Korthi Andros	37.46	24.58	8/01	0-3	24.04	38.18	36.8
Kastro Andros	37.51	24.57	8/01	0-3	24.04	38.18	34.5
Kalamos	38.31	24.14	6/08	0-3	21.53	38.01	71.2
Katerini	40.23	22.39	6/08	0-3	21.44	37.07	0.0
Nea Kallikratia	40.23	22.55	6/08	0-3	21.44	37.07	3.0
Avdira	40.56	24.57	6/08	0-3	21.41	35.52	0.0

cal agglomerative clustering was performed using SPSS (version 10.1) statistical software.

All the samples and the SEM micrographs are kept in the collections of the Museum of Paleontology and Geology of the University of Athens.

## Results

### Temperature and Salinity

During the samplings the surface water showed a mean monthly temperature higher than 18.26 °C, whereas salinity varied between 35.52‰ and 39.03‰ (Table 1). The highest temperature was observed in July (24.45 °C) at Chrissi and the lowest (18.26 °C) in May at Vravron. Salinity increased towards south, where surface higher values were found at the southernmost sampling site (Chrissi). The high river discharges into semi-closed gulfs of the northern Aegean Sea (Fig. 1) caused low salinity at the sampling sites of Avdira, Katerini and N. Kallikratia.

### Foraminiferal community structure

Benthic foraminifera were rich in all the studied samples. In general, the foraminiferal assemblages were dominated by genera with calcareous tests (hyaline and porcelaneous).

The porcelaneous forms (Fig. 2a, b) comprise an important component of the fauna, comprising about 50% of the total assemblages and are mainly represented by members of the genera *Peneroplis*, *Quinqueloculina*, *Miliolinella*, *Sorites* and *Triloculina*. The hyaline taxa (Fig. 2a, b) generally showed high relative abundances (comprising about 40% of the total assemblages) and are represented mostly by the genera *Amphistegina*, *Rosalina*, *Elphidium*, *Ammonia*, *As-*

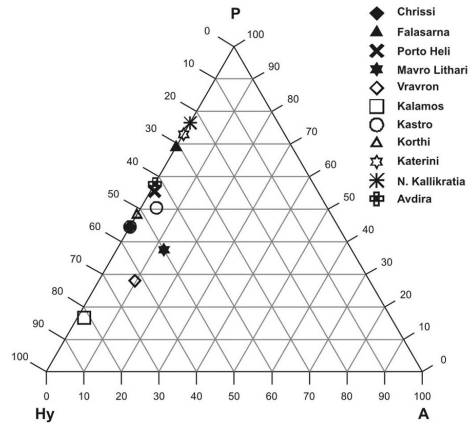

a)

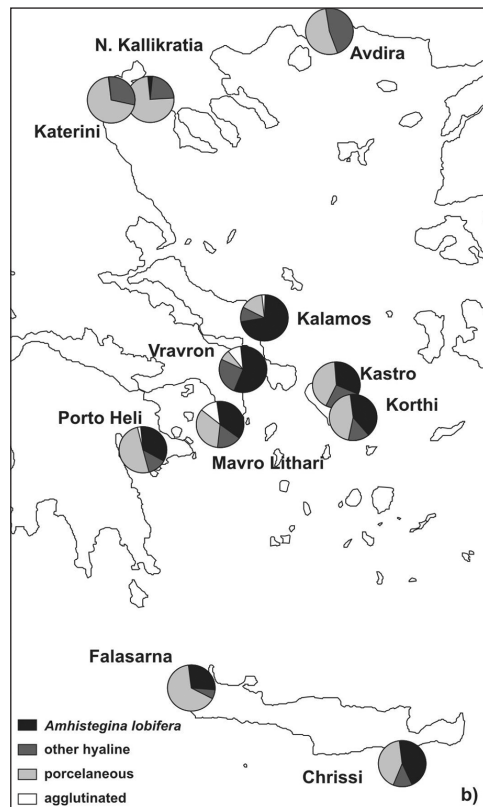

b)

**Fig. 2:** a Ternary plot of walls for foraminiferal assemblages (triangle corners represent 100% of the labeled component: A= agglutinated, P= porcelaneous, Hy= hyaline). b Pie charts determining the distribution of *A. lobifera* for each studied site.

*terigerina* and *Cymbaloporetta*. Agglutinated components (Fig. 2a, b) are rare with low frequencies (less than 15% of the foraminiferal assemblage), mainly represented by *Textularia* species.

The most abundant species is the hyaline *A. lobifera* Larsen, which is the dominant foraminifer on the coasts at the southern and central Aegean sites. According to Fig. 2b, the highest relative abundances were observed at the sampling sites of Kalamos and Vravron where it composed 71.2% and 55.5% of the foraminiferal assemblages respectively. In the northern sites the species show a dramatic abundance decline with very low frequencies (0.3% of the foraminiferal assemblages at the sampling site of N. Kallikratia) or totally absent (Avdira and Katerini).

### Q-mode statistical analysis

Q-mode hierarchical cluster analysis was applied to determine the degree of similarity in foraminiferal species composition be-

tween the studied sites. The resulting dendrogram (Fig. 3) revealed two main groups: Cluster I comprised of three sites (N. Kallikratia, Katerini and Avdira), whereas Cluster II was in turn subdivided into three sub-clusters: IIa, IIb and IIc. Cluster IIa groups Chrissi, Porto Heli and Falasarna, Cluster IIb includes Korthi, Kastro and Mavro Lithari, whereas Vravron and Kalamos clustered in Cluster IIc.

Comparing the distribution of the clusters it becomes obvious that the assemblage differentiation is associated with the geographic distribution of the sampling sites. Cluster I separates the sites from the northern Aegean Sea. The foraminiferal assemblage is characterized by very low proportions or absence of *A. lobifera*. *Quinqueloculina* is present with the highest relative abundances (ranging between 35 and 45%), whereas *Elphidium* and *Ammonia* are significant components with relative high frequencies (up to 10%; Fig. 4). Cluster IIc and Cluster IIb are located in the central Aegean

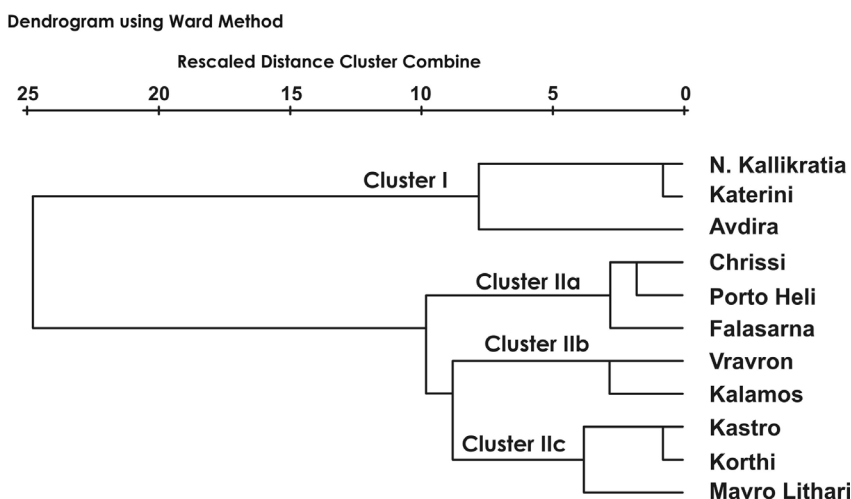

**Fig. 3:** Dendrogram resulting from a Q-mode hierarchical cluster analysis (Ward's method and Euclidean distances as a similarity index) based on a correlation matrix of the statistically important foraminiferal species.

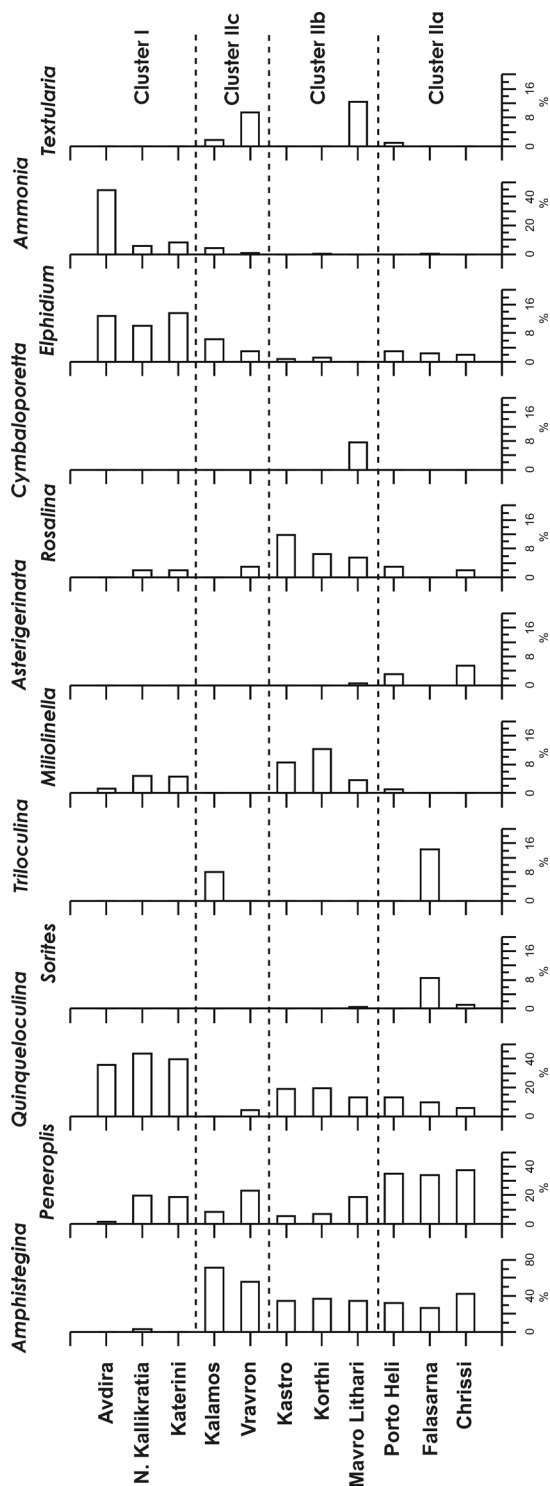

Fig. 4: Relative abundance (%) of the most indicative foraminiferal taxa for all sampling sites.

Sea. The foraminiferal assemblage of Cluster IIc is dominated by *A. lobifera* (with relative abundance up to 50%), whereas this species represents 35% on average of Cluster IIb (Fig. 4). In the latter assemblage *Quinqueloculina* ranges between 13-20%, whereas *Rosalina* and *Miliolinella* occur with high relative abundances of approximately 10% (Fig. 4). The localities from the east Peloponnesus and the southern Aegean Sea correspond to Cluster IIa. The foraminiferal assemblage is distinguished by the highest frequencies of *Peneroplis* (35% on average). *A. lobifera* ranges between 26 and 43% of the foraminiferal assemblage (Fig. 4).

## Discussion

The present study shows that the main factor that determines the distribution of summer epiphytal benthic foraminiferal assemblages in the Aegean Sea is the geographical location (mainly latitude and temperature).

The assemblages include diverse forms of the morphotypes recognized by LANGER (1993). In the south, the permanently motile grazer *Peneroplis* (type D; LANGER, 1993) and *A. lobifera* actually prevail in the communities; *A. lobifera* dominates, followed by the permanently motile grazers *Quinqueloculina* and

*Miliolinella* (type D; LANGER, 1993) and the temporarily attached *Rosalina* (type B; LANGER, 1993) in the central Aegean. In the north, *A. lobifera* is decreasing against *Quinqueloculina* (type D; LANGER, 1993) and the stress-tolerant motile species *Elphidium* (type C; LANGER, 1993) and *Ammonia*, which may characterize areas of high biological oxygen demand (HALLOCK *et al.*, 2003). Consequently, *A. lobifera* is a significant component of the epiphytic foraminiferal fauna in Greek coastal ecosystems.

*A. lobifera* LARSEN 1976 belongs to the family Amphisteginidae Cushman and the genus *Amphistegina* d'Orbigny. This species is a flat trochospiral, biconvex, lenticular, large foraminifer (Plate I). The test is characterized by thick-walls, often globular, with the spiral side being more pronounced than the umbilical side. The main distinctive features of the species are the lobate septa visible on both sides of large adult tests. Younger individuals do not show these strong lobes, and very small specimens are extremely similar to the related species *A. lessonii* (HOHENEGGER *et al.*, 1999). It is a well-known algal symbiont-bearing benthic foraminifer that lives in warm, clear and nutrient deficient environments (HALLOCK, 1988). The thick-walled test allows this species to live in the highest light-energy levels (HALLOCK, 1981). Several studies (HUGHES, 1977; MURRAY, 1991; HALLOCK, 1996, 1998, 2000) proposed this species as indicator for coral reef water quality without fluctuations of salinity and oxygen and TRIANTAPHYLLOU *et al.* (2005) considered it as a bioindicator of coastal health in the Aegean Sea.

Larger foraminifera have developed complex internal structures adapted to symbiotic relationships (LEE & HALLOCK, 1987; LEE, 1998), as symbiosis can be high-

ly advantageous. The host-symbiont system plays an important role in supplying carbon for photosynthesis by the algal symbionts (TER KUILE *et al.*, 1987) and enhancement of foraminiferal calcification (DUGUAY, 1983; TER KUILE, 1991; TOLER & HALLOCK, 1998; EREZ, 2003). HALLOCK (1981), VÉNEC-PEYRÉ (1991) and HALLOCK *et al.* (2003) suggest probable advantages of large foraminiferal feeding from photosynthetic symbionts when dissolved inorganic nutrients and particulate food sources are scarce. In the studied samples from the Aegean Sea, the SEM observations indicated the presence of pennate diatom symbionts in specimens of *A. lobifera* (Plate I). These specimens are characterized by a visible green to golden-brown symbiont color.

The geographical distribution of *A. lobifera* comprises the shallow water environments in the Indian, Pacific and Atlantic Oceans (LANGER & HOTTINGER 2000). According to MORARIU & HOTTINGER (1988), LANGER & HOTTINGER, (2000) the occurrence of living amphisteginids is delimited by the 14 °C winter isotherm. The Mediterranean occurrences of the amphisteginids are limited to the Levantine Basin and to large parts of the coast of Africa (LANGER & HOTTINGER 2000; LANGER, 2008a). During migration via the Suez Canal (Lessepsian), their distribution generally follows both clockwise and anti-clockwise directions (LANGER, 2008a) and appears to express rapid expansion in the Mediterranean Sea. *A. lobifera* has been recorded in Greece (CHERIF, 1970; TRIANTAPHYLLOU *et al.*, 2005; KOUKOUSIOURA *et al.*, 2006) and Cyprus (LANGER & HOTTINGER, 2000), Israel (HYAMS *et al.*, 2002; GRUBER *et al.*, 2007), Lebanon (MONCHARMONT ZEI, 1968), the Mediterranean coasts of Turkey



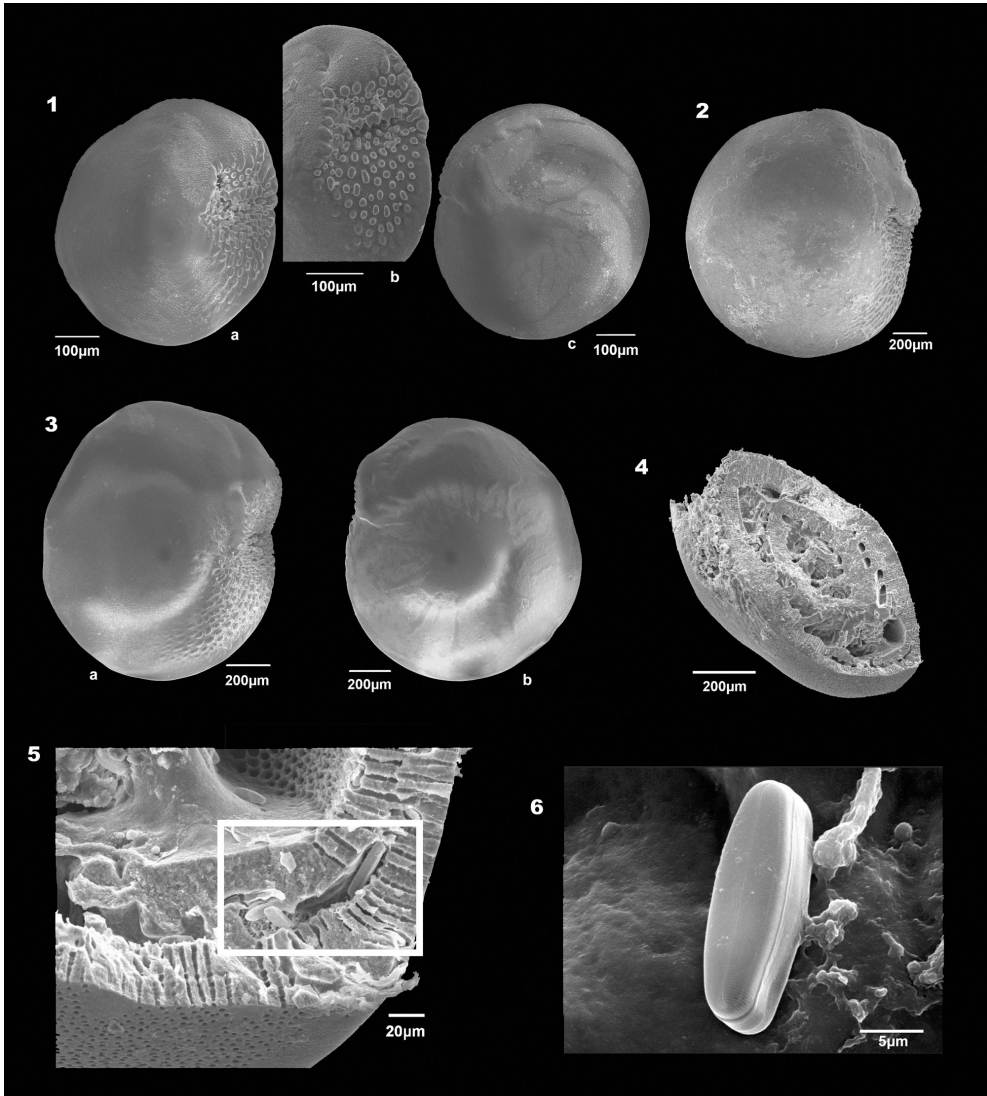

**Plate I:** *Amphistegina lobifera* Larsen **1a** ventral view, **1b** aperture details, **1c** dorsal view, Andros site; **2** ventral view, Vravron site; **3a** ventral view, **3b** dorsal view, Chrissi site; **4** details of internal structure; **5** symbiotic diatoms within *A. lobifera* marginal canal system **6a** pennate symbiotic diatom within *A. lobifera* host, Andros site.

(AVŞAR, 1997; MERİÇ *et al.*, 2008), the Sea of Marmara (MERİÇ *et al.*, 2005) and on the coasts of the Maltese Islands (YOKES *et al.*, 2007).

This species has been included among the invasive species in the Mediterranean

that cause change to the habitat type and coastal structure in the eastern Mediterranean (STREFTARIS & ZENETOS, 2006). However, *A. lobifera* together with the rest of the larger symbiont-bearing species is considered to be a major carbonate producer

in the shallow water and reef environments precipitating up to 2kg/m<sup>2</sup>/year (LANGER *et al.*, 1997; LANGER, 2008b), therefore it successfully provides enough sediment for receding eastern Mediterranean beaches.

Although apparently spreading from the Suez Canal (e.g. LANGER & HOTTINGER, 2000), amphisteginids have also been found in Pliocene Mediterranean deposits (DI BELLA *et al.*, 2005), obviously representing Atlantic migrants after the Messinian salinity crisis (LANGER & HOTTINGER, 2000), as Miocene occurrences are unlikely to have survived this event. Nowadays the Atlantic coastline off Gibraltar is barren of amphisteginids (LEVY *et al.*, 1995) as temperatures are too low. However, according to LANGER (2008a), already in 1839 D'ORBINGY identified viable populations of living amphisteginids that most probably used the Canary Islands in order to repeatedly invade the Mediterranean Sea. It is therefore questionable if all the Mediterranean amphisteginids are true Lessepsian migrants or of different origin, such as the Atlantic (LANGER, 2008a). In this study, additional sites of occurrences were found on distributional range and settlement of the alien species *A. lobifera* in Greek coastal ecosystems.

The high relative abundances recorded are the result of the very successful inhabitation of this species in the Aegean ecosystems and suggest that it has become a significant part of the epiphytic foraminiferal fauna. In general, larger foraminifera are K strategists that slowly achieve populations due to long individual life, but in shallow water they become r strategists that opportunistically increase in number when conditions are favourable (MURRAY, 2008). Therefore the intense presence of *Amphistegina* suggests oligotrophic environmental conditions, yet it also provides evi-

dence of a change in the life strategy of the species in Aegean coastal environments. Detailed future studies of annual population dynamics of *A. lobifera* on a seasonal basis will reveal its role in the different coastal ecosystems of the Aegean Sea and its impact on 'indigenous' foraminiferal faunas.

## Acknowledgements

Financial support for this study was provided by Research Project 70/4/8644 of the University of Athens. Special thanks are due to M. Langer, an anonymous reviewer and the Journal editor A. Zenetos for providing constructive criticism on the manuscript.

## References

- AVŞAR, N., 1997. Foraminifera of the Eastern Mediterranean Coastline. *Ç.Ü. Yerbilimleri Geosound*, 31: 67-81.
- CHERIF, O.H., 1970. Die Miliolacea der West-Küste von Naxos (Griechenland) und ihre Lebensbereiche. *Ph.D. Thesis*, University of Clausthal (Germany), 175 pp.
- DI BELLA, L., CARBONI, M.G. & PIGNATTI, J., 2005. Paleoclimatic significance of the Pliocene *Amphistegina* levels from the Tyrrhenian margin of Central Italy. *Bolletino della Societa Paleontologica Italiana*, 44(3): 219-229.
- DUGUAY, L.E., 1983. Comparative laboratory and field studies on calcification and carbon fixation in foraminiferal-algal associations. *Journal of Foraminiferal Research*, 13: 252-261.
- EREZ, J., 2003. The source of ions for biomineralization in foraminifera and their implications for paleoceanographic proxies. In: *Biomineralization*. P.M. Dove, J.J. De Yoreo & Weiner S. (Eds), *Re-*

- views in *Mineralogy and Geochemistry*, 54: 115–149.
- GRUBER, L., LAZAR, S., HYAMS, O., SIVAN, D., HERUT, B. & ALMOGI-LABIN, A., 2007. *Amphistegina lobifera*, a larger symbiont-bearing foraminiferal migrant from the Red Sea, now dominates rocky coasts of the Israeli Mediterranean. *Geophysical Research Abstracts*, 9, 01407.
- HALLOCK, P., 1981. Algal symbiosis: a mathematical analysis. *Marine Biology*, 62: 249-255.
- HALLOCK, P., 1984. Distribution of selected species of living algal symbiont-bearing foraminifera on two Pacific coral reefs. *Journal of Foraminiferal Research*, 14: 250-261
- HALLOCK, P., 1988. The role of nutrient availability in bioerosion: Consequences to carbonate buildups. *Palaeogeography, Palaeoclimatology, Palaeoecology*, 63: 275-291.
- HALLOCK, P., 1996. *Amphistegina* (Foraminiferida) densities as a practical, reliable, low-cost indicator of Coral Reef vitality. In: *A coral reef symposium on practical, reliable, low cost monitoring methods for assessing the biota and habitat conditions of coral reefs*. M.P. Crosby, G.R. & K.W. Gibson Potts (Eds), January 26-27, 1995, Office of Ocean and Coastal Resource Management, National Oceanic and Atmospheric Administration, Silver Spring, MD, 37-44 pp.
- HALLOCK, P., 1998. Foraminifera as ecosystem indicators: Phase 1- A marine benthic perturbation index; Phase 2- Bioassay protocols. *Proc. 1996/97 Star grants ecological assessment/ ecosystem indicators Program Review*, February 3-5, 1998, Las Vegas, Nevada, U.S. Environmental Protection Agency, 9-10 pp.
- HALLOCK, P., 1999. Symbiont-bearing foraminifera. In: *Modern Foraminifera*. B. Sen Gupta (Ed.), Amsterdam: Kluwer Press, 123-139 pp.
- HALLOCK, P., 2000. Larger foraminifera as indicators of coral-reef vitality. In: *Environmental Micropaleontology*. R.E. Martin (Ed.), Plenum Press Topics in Geobiology, 121-150 pp.
- HALLOCK, P., LIDZ, B.H., COCKEY-BURKHARD, E.M. & DONNELLY, K.B., 2003. Foraminifera as bioindicators in coral reef assessment and monitoring: the FORAM Index. *Environmental Monitoring and Assessment*, 81(1-3): 221–238.
- HANSEN, H.J. & BUCHARDT, B., 1977. Depth distribution of *Amphistegina* in the Gulf of Elat, Israel. *Utrecht Micropaleontological Bulletin*, 15: 205- 224.
- HOHENEGGER, J., 1994. Distribution of living larger foraminifera NW of Sesoko-Jima, Okinawa, Japan. *Marine Ecology*, 15: 291-334.
- HOHENEGGER, J., 1996. Remarks on the distribution of larger foraminifera (Protozoa) from Belau (Western Carolines). *Occasional Papers, Kagoshima University, Kagoshima University Research Center for the South Pacific*, Korimoto 30: 85-90.
- HOHENEGGER, J., YORDANOVA, E., NAKANO, Y. & TATZREITER, F., 1999. Habitats of larger foraminifera on the upper reef slope of Sesoko Island, Okinawa, Japan. *Marine Micropaleontology*, 36 (2-3): 109-168.
- HOLLAUS, S. & HOTTINGER, L., 1997. Temperature dependence of endosymbiotic relationships? Evidence from the depth range of Mediterranean *Amphistegina lessonii* (Foraminiferida) truncated by the thermocline. *Eclogae geologicae Helvetiae*, 90(3): 591-597.
- HUGHES, G., 1977. Recent foraminifera

- from the Honiara Bay area, Solomon Islands, *Journal of Foraminiferal Research*, 7: 45–57.
- HYAMS, O., ALMOGI-LABIN, A. & BENJAMINIA, C., 2002. Larger foraminifera of the southeastern Mediterranean shallow continental shelf off Israel. *Israel Journal of Earth Sciences*, 51(3/4): 169-179.
- HYAMS-KAPHZAN, O., ALMOGI-LABIN, A., SIVAN, D. & BENJAMINI, C., 2008. Benthic foraminifera assemblage change along the southeastern Mediterranean inner shelf due to fall-off of Nile-derived siliciclastics. *Neues Jahrbuch für Geologie und Paläontologie*, 248: 315-344.
- KOUKOUSIOURA, O., TRIANTAPHYLLOU, M.V., TSOUROU, T., DIMIZA, M. & DERMITZAKIS, M.D., 2006. The role of *Amphistegina lobifera* as an environmental health proxy in coastal environments: a case study from Kastro and Korthi gulfs (Andros Island, middle Aegean Sea, Greece). *International Symposium of Foraminifera, FORAMS 2006, 10-15 September 2006, Natal, Brazil, Anuario do Instituto de Geociencias, Universidade Federal do Rio de Janeiro*, vol. 29-1, 268 p.
- LACOMBE, H. & TCHERNIA, P., 1972. Caractères hydrologiques et circulation des eaux en Méditerranée. In: *The Mediterranean Sea*. DJ Stanley (Ed.) Dowden Hutchinson & Ross, Stroudsburg, PA, 26–36 pp.
- LANGER, M.R., 1993. Epiphytic Foraminifera. In: Martin R. Langer (Ed.) Foraminiferal Microhabitats, Special Issue Marine Micropaleontology. *Marine Micropaleontology*, 20: 235-265.
- LANGER, M.R., 2008a. Foraminifera from the Mediterranean and the Red Sea. *Aqaba-Eilat, the Improbable Gulf. Environment, Biodiversity and Preservation*. F.D. Por (Ed.) Magnes Press, 399-417 pp.
- LANGER, M.R., 2008b. Assessing the contribution of foraminiferal protists to global ocean carbonate production. *Journal of Eukaryotic Microbiology*, 55(3): 163-169.
- LANGER, M.R. & HOTTINGER, L., 2000. Biogeography of selected "larger" foraminifera, *Micropaleontology*, Supplement, 46: 105-126.
- LANGER, M.R., SILK, M.T. & LIPPS, J.H., 1997. Global ocean carbonate and carbon dioxide production: The role of reef foraminifera. *Journal of Foraminiferal Research*, 27: 271-277.
- LARSEN, A.R., 1976. Studies of Recent *Amphistegina*, taxonomy and some ecological aspects. *Israel Journal of Earth Sciences*, 25: 1-26.
- LEE, J.J., 1998. Living sands. *BioScience*, 45: 252-261.
- LEE, J.J. & HALLOCK, P., 1987. Algal symbiosis as a driving force in the evolution of larger foraminifera. *Annals, New York Academy of Science*, 503: 330–47.
- LEVY, A., MATHIEU, R., POIGNANT, A., ROSSET-MOULINIER, M. & AMBROISE, D., 1995. Benthic foraminifera from the Fernando de Noronha Archipelago (northern Brazil). *Marine Micropaleontology*, 26: 89-97.
- LOEBLICH, A.R. & TAPPAN, H., 1988. *Foraminiferal Genera and their Classification*. Van Nostrand and Reinhold, New York, (2 vols) 2047 pp.
- MERİÇ, E., AVŞAR, N., NAZİK, A., ALPAR, B., YOKEŞ, B., BARUT, İF. & ÜNLÜ, S., 2005. Gemlik Körfezi Yüze Çökellerinin Foraminifer, Ostrakod ve Mollusk Faunası, Foraminifer Kavkaları nda Gözlenen Morfolojik Anomaliler ile Bölgenin Sedimentolojik, Hidrokimyasal ve Biokimyasal Özellikleri. *Maden Tetkik*

- Arama Dergisi*, 131: 21-48.
- MERICİ, E., AVŞAR, N. & YOKEŞ, M.B., 2008. Some alien foraminifers along the Aegean and southwestern coasts of Turkey. *Micropaleontology*, 54: 307-349.
- MONCHARMONT ZEI, M., 1968. I foraminiferi di alcuni campioni di fondo prelevati lungo la costa di Beirut (Libano). *Bolletino Societa Naturalisti di Napoli*, 77: 3-34.
- MORARIU, A. & HOTTINGER, L., 1988. Amphisteginid specific identifications, dimorphism, coiling direction and provincialism. *Revue de Paléobiologie*, Volume Special, 2: 695-698.
- MURRAY, J.W., 1991. *Ecology and Palaeoecology of Benthic Foraminifera*. Longman, Wiley, Harlow/Essex, New York, NY, 397 pp.
- MURRAY, J.W., 2008. *Ecology and Applications of Benthic Foraminifera*. Cambridge University Press, Cambridge, 426 pp.
- MURRAY, J.W. & BOWSER, S.S., 2000. Mortality, protoplasm decay rate, and reliability of staining techniques to recognise 'living' foraminifera: a review. *Journal of Foraminiferal Research*, 30: 66-70.
- ORBIGNY, A.D. D', 1839. Foraminifères. In: P. Barker-Webb & S. Berthelot (Eds), *Histoire naturelle des Iles Canaries*, II (2), 119-146 pp.
- POULOS, S.E., DRAKOPOULOS, P.G. & COLLINS, M.B., 1997. Seasonal variability in sea surface oceanographic conditions in the Aegean Sea (Eastern Mediterranean): an overview. *Journal of Marine Systems*, 13: 225-244.
- REISS, Z. & HOTTINGER, L., 1984. The Gulf of Aqaba; Ecological micropaleontology. In: *Ecological Studies*, 50, Springer-Verlag, Berlin, Federal Republic of Germany, 1-354 pp.
- RENEMA, W. & TROELSTRA, S.R., 2001. Larger foraminifera distribution on a mesotrophic carbonate shelf in SW Sulawesi (Indonesia). *Palaeogeography, Palaeoclimatology, Palaeoecology*, 175: 125-146.
- STREFTARIS, N. & ZENETOS, A., 2006. Alien marine species in the Mediterranean – the 100 'worst invasives' and their impacts. *Mediterranean Marine Science*, 7/1: 87-118.
- TER KUILE, B., 1991. Mechanisms for calcification and carbon cycling in algal symbiont-bearing foraminifera. In: *Biology of Foraminifera*. J.J. Lee & O.R. Anderson (Eds), Academic Press, London, 73-90 pp.
- TER KUILE, B., EREZ, J. & LEE, J.J., 1987. The role of feeding in the metabolism of larger, symbiotic foraminifera. *Symbiosis*, 4: 335-50.
- THEOCHARIS, A. & GEORGOPOULOS, D., 1993. Dense water formation over the Samothraki and Limnos Plateaux in the North Aegean Sea (Eastern Mediterranean Sea). *Continental Shelf Research*, 13(8/9): 919-939.
- TOLER, S.K. & HALLOCK, P., 1998. Shell malformation in stressed *Amphistegina* populations: relation to biomineralization and paleoenvironmental potential. *Marine Micropaleontology*, 34: 107-15.
- TRIANANTAPHYLLOU, M.V., TSOUROU, T., KOUKOUSIOURA, O. & DERMITZAKIS, M.D., 2005. Foraminiferal and ostracod ecological patterns in the coastal environments of SE Andros Island (Middle Aegean Sea, Greece). *Revue de Micropaleontologie*, 48: 279-302.
- VÉNEC-PEYRÉ, M.-T., 1991. Distribution of living benthic foraminifera on the back-reef and outer slopes of a high island (Moorea, French Polynesia). *Coral Reefs*, 9: 193-203.
- WALTON, W.R., 1952. Technique for recognition of living foraminifera. Contribu-

- tions from the Cushman Foundation. *Journal of Foraminiferal Research*, 3: 56–60.
- YOKEŞ, B., MERİÇ, E. & AVŞAR, N., 2007. On the presence of alien foraminifera *Amphistegina lobifera* Larsen on the coasts of the Maltese Islands. *Aquatic Invasions*, 2/4: 439–441.
- ZENETOS, A., ÇINAR, M.E., PANCUCCI-PAPADOPOULOU, M.A., HARME-LIN, J.G., FURNARI, G., ANDALORO, F., BELLOU, N., STREFTARIS, N. & ZIBROWIUS, H., 2005. Annotated list of marine alien species in the Mediterranean with records of the worst invasive species. *Mediterranean Marine Science*, 6 (2): 63-118.
- ZENETOS, A., MERİÇ, E., VERLAQUE, M., GALLI, P., BOUDOURESQUE, CF., GIANGRANDE, A., ÇINAR, M.E. & BILECENOGLU, M., 2008. Additions to the annotated list of marine alien biota in the Mediterranean with special emphasis on Foraminifera and Parasites. *Mediterranean Marine Science*, 9/1: 119-165.

*Submitted: June 2009*

*Accepted: June 2009*

*Published on line: September 2009*

